



West Campus Area Plan
University of California, Riverside

West Campus Area Plan

University of California, Riverside

March, 2003

Prepared by:

BMS Design Group

Urban Design
Land Planning
Landscape Architecture

414 Jackson Street, Suite 404
San Francisco CA 94111

In association with:

Kennedy Jenks Consultants

Engineers & Scientists

2151 Michelson Drive, Suite 100
Irvine CA 92612

TABLE OF CONTENTS

Introduction	1-1
Purpose of the Plan	1-3
Participants and Contributors	1-3
Related Plans	1-4
Planning Context	2-1
Existing Site Configuration	2-3
Existing Uses and Facilities	2-3
Existing Access	2-6
Facility Program	2-6
Plan Elements	3-1
Plan Influences and Themes	3-3
Plan Framework	3-8
Land Use	3-10
Parcel Plan	3-14
Circulation and Parking Plan	3-16
Open Space Plan	3-26
Utilities and Infrastructure	3-32
Development Strategy	4-1
Phasing Strategy	4-4
Infrastructure Costs	4-10
Implementation Elements	4-21
Design Guidelines	5-1
Introduction	5-3
Design Principles	5-4
Academic Area Guidelines	5-7
Academic Districts & Special Buildings Guidelines	5-15
Residential Area Guidelines	5-28
Landscape Guidelines	5-32

LIST OF FIGURES

Figure 1	2003 LRDP Land Use Plan	1-5
Figure 2	Existing citrus groves	2-4
Figure 3	International Village housing	2-4
Figure 4	Parking Lot 30	2-4
Figure 5	The Gage Canal	2-4
Figure 6	Existing UCR West Campus facilities and uses	2-5
Figure 7	Historic Southern California citrus crate art.	3-4
Figure 8	Citrus Experiment Station at Mt. Rubidoux	3-4
Figure 9	The Citrus Experiment Station in 1948	3-5
Figure 10	Citrus Experiment Station	3-5
Figure 11	Plan Framework	3-9
Figure 12	Land Use Plan	3-11
Figure 13	Parcel Plan	3-15
Figure 14	Vehicular Circulation and Parking Plan	3-17
Figure 15	Bicycle Circulation Plan	3-19
Figure 16	Transit Circulation Plan	3-21
Figure 17	Parking Plan	3-23
Figure 18	Service and Emergency Access Plan	3-25
Figure 19	Open Space Plan	3-27
Figure 20	The Grove	3-28
Figure 21	The Grove	3-28
Figure 22	Canyon Crest Mall	3-29
Figure 23	The Grove Frame	3-29
Figure 24	Gage Mall	3-30
Figure 25	Sewer System Plan	3-33
Figure 26	Sewer Catchment Zones	3-34
Figure 27	Drainage Plan	3-37
Figure 28	Water Plan	3-39
Figure 29	Gas Plan	3-41
Figure 30	Electrical Plan	3-42
Figure 31	Transmission Line Plan	3-43
Figure 32	Initial Development Stage	4-5
Figure 33	Intermediate Stage	4-7
Figure 34	Ultimate Development Stage	4-9
Figure 35	Infrastructure Project Phasing: Initial Development Stage	4-11

Figure 36	Infrastructure Project Phasing: Intermediate Stage	4-12	Figure 70	University Mall / Canyon Crest Mall	5-40
Figure 37	Infrastructure Project Phasing: Ultimate Development Stage	4-13	Figure 71	Northwest Mall / Southwest Mall	5-41
Figure 38	Agricultural buildings	5-5	Figure 72	Gage Mall	5-41
Figure 39	The UCSC Student Center	5-5	Figure 73	Neighborhood Parks	5-42
Figure 40	Humanities complex	5-5	Figure 74	Streetscape, Gateways and Buffer Key	5-43
Figure 41	New apartment housing	5-6	Figure 75	Martin Luther King Boulevard	5-44
Figure 42	New family housing	5-6	Figure 76	Iowa Avenue	5-45
Figure 43	Narrow streets	5-6	Figure 77	Local Access Streets	5-46
Figure 44	Building Types	5-8	Figure 78	Pedestrian Connectors	5-46
Figure 45	Build To Lines	5-9	Figure 79	Service Routes and Areas	5-47
Figure 46	Special Buildings	5-10	Figure 80	Canyon Crest Gateway	5-49
Figure 47	Primary Building Entry	5-11	Figure 81	Gage Gateway	5-50
Figure 48	Building Porches, Verandas, and Arcades Illustrative Cross Sections	5-12	Figure 82	Gateways to West Parking at Martin Luther King Boulevard	5-50
Figure 49	Building Porches, Verandas, and Arcades	5-12	Figure 83	Landscape Buffer	5-52
Figure 50	Focal Points and Axes	5-13			
Figure 51	Academic Districts and Special Building Overview	5-15			
Figure 52	The Grove District	5-16			
Figure 53	Inner Grove Buildings	5-17			
Figure 54	University Mall District	5-18			
Figure 55	University Avenue Mixed Use Building	5-19			
Figure 56	Gage Mall District	5-20			
Figure 57	North Entry Axis Building	5-21			
Figure 58	Canyon Crest Mall District	5-22			
Figure 59	Grove / East Entry Building	5-23			
Figure 60	University Mall South	5-24			
Figure 61	Southeast District	5-25			
Figure 62	Southwest District	5-26			
Figure 63	South West Parking Structures	5-27			
Figure 64	Residential Setbacks	5-29			
Figure 65	Illustrative Family Housing Neighborhood Block	5-31			
Figure 66	Landscape Framework	5-35			
Figure 67	The Grove	5-37			
Figure 68	West Campus Malls and Neighborhood Park Key	5-39			
Figure 69	Grove Frame	5-40			

LIST OF TABLES

Table 1	West Campus Academic and Support Facilities Program	2-7
Table 2	West Campus Housing Program	2-7
Table 3	West Campus Land Use Acreages	3-10



INTRODUCTION

INTRODUCTION

Purpose of the Plan

The West Campus Area Plan presents plans and guidelines for the long term, orderly development of the western portion of the University of California, Riverside (UCR) campus. The need to expand the campus within this area is prompted by increasing enrollment at UCR, and the expansion and replacement of academic buildings, housing, athletic fields, and other facilities associated with the operation of this research university campus.

The West Campus Area Plan consists of text, plans and other graphics intended to convey the organization, phasing and character of expansion of the existing campus onto a portion of university-owned lands lying west of the I-215/SR-60 freeway from the current academic core. The West Campus is generally defined as the land bounded by the I-215/SR-60 freeway to the east, Martin Luther King Boulevard to the south, Chicago Avenue to the west and University Avenue/Everton Place to the north.

The plan will guide decision-making regarding the location of facilities and the timing of supporting infrastructure such as streets and utilities. It also includes guidelines for site, building, and landscape design and consequently will provide a tool for guiding and evaluating the preparation of future facility proposals.

Participants and Contributors

The West Campus Area Plan was prepared with the active participation of two important committees. The West Campus Advisory Committee met regularly to review plan concepts and provided invaluable ideas and comments

throughout the process. This committee included:

- Pat O'Brien, Dean, College of Humanities, Arts and Social Sciences
- Jack Azzaretto, Vice Chancellor, Public Service and International Programs and Dean, University Extension
- Richard Block, Professor of Mathematics, Academic Senate Physical Resources Planning Committee representative
- Don Dye, Dean, A. Gary Anderson Graduate School of Management
- Lindy Fenex, Director, Student Recreation Center
- Andy Plumley, Director, Housing

A Working Committee comprising UCR staff also provided regular technical information and guidance throughout the planning process. This committee included:

- Lisa Peloquin (Project Manager) Academic Planning and Budget - Capital and Physical Planning
- Gretchen Bolar, Vice Chancellor for Academic Planning and Budget
- Nita Bullock, Academic Planning and Budget - Capital and Physical Planning
- Luis Carrazana, Academic Planning and Budget - Capital and Physical Planning
- Lindy Fenex, Student Recreation Center
- Earl LeVoss, Physical Plant
- Andy Plumley, Housing Services
- Tricia Thrasher, Design and Construction

Related Plans

2003 Long Range Development Plan

The UC Riverside Long Range Development Plan (LRDP), provides program and general planning direction for the West Campus Area Plan. The 2003 LRDP is an update to the previous LRDP, adopted in 1990. The updated plan was prepared to account for significant changes facing the University. In the 1990 plan, student enrollment was projected to reach 18,050 (head count) by the year 2005-06; the 2003 LRDP acknowledges and plans for further growth to an enrollment of 25,000 (head count), by the year 2015.

The 2003 LRDP sets out planning principles and an overall land use plan for the entire campus. It also includes elements discussing circulation, parking, utilities and infrastructure, and sustainable design and planning practices which serve as a guide and starting point for the more detailed planning framework and design recommendations of this West Campus Area Plan. The 2003 LRDP land use plan is shown in Figure 1.

An overall strategy of the LRDP is to consolidate and concentrate academic and other uses to the degree possible to ensure a campus that is easily accessible by pedestrians and bicyclists. However, the building program projected to be required to support the 25,000 student head count enrollment requires significantly more land area than is available east of the I-215/SR-60 freeway, even if a considerable intensification of future building densities is assumed. Therefore, as shown on the 2003 LRDP land use plan, academic, housing and athletics/recreational areas will be required in the future on the West Campus in order to meet the overall campus program projections. Consequently, a key goal in the development of the West Campus is to unify the East and West Campuses and provide the most easy and direct access for students, faculty and staff as possible.

University Community Plan

The City of Riverside has recently prepared An Addendum to the University Community Plan, originally prepared in 1986. The University Community Plan is intended to address planning and development issues in an extensive area surrounding but largely west of UCR. The addendum was prepared in parallel with the 2003 LRDP for UCR, in order to identify areas of mutual interest and concern.

The Addendum to the University Community Plan and the 2003 UCR LRDP identify a number of concepts that relate directly and are of particular importance to the future development of the West Campus. Among these key concepts are:

Figure 1 2003 LRDP Land Use Plan

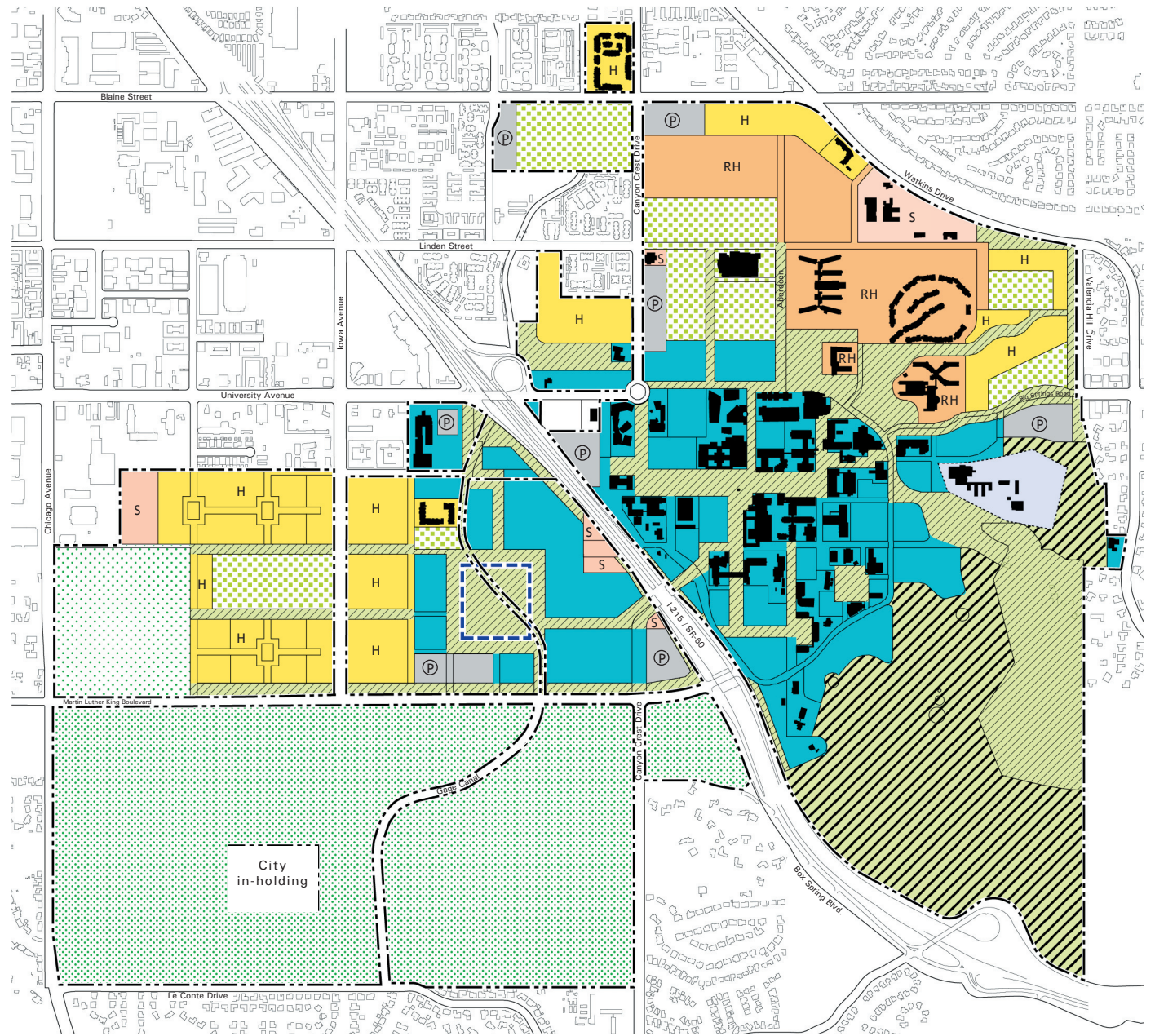
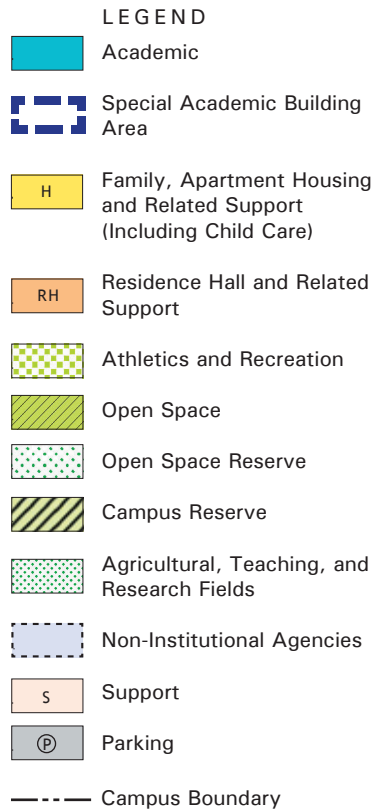

Intensification and redevelopment of University Avenue between the I-215/SR-60 freeway and Chicago Avenue.

This portion of University Avenue is envisioned to become a “Main Street” of the University and Riverside community, hosting retail, entertainment, and service uses of benefit both to the campus and the local community. In addition, there is ample development capacity within this zone to accommodate considerable additional student, faculty and staff housing. The Addendum to the University Community Plan and the LRDP both identify opportunities to redevelop parcels along University Avenue in a far more intense, mixed use configuration, that might include retail on the ground floor, with office and/or residential units above. This kind of intensification could lead to a far higher level of pedestrian activity, throughout the day and evening.

Improvements to University Avenue Pedestrian Environment.

At various times of the day, the volumes of traffic entering and exiting the freeway interchange at University Avenue result in an environment dominated by vehicular traffic and discouraging of pedestrian and bicycle use. Vehicular conflicts with pedestrians crossing under the freeway on the south side of University Avenue are severe. To rectify this it is envisioned that the southbound on-ramp from University Avenue on to the freeway will be narrowed (from two lanes to one) and configured to provide an improved environment for pedestrians crossing between the West and East Campuses. In addition, the intensification of uses along University Avenue, with additional sidewalk improvements all the way to Chicago, will encourage an active pedestrian environment.

Long term diversion of freeway traffic to the Blaine and Martin Luther King Boulevard interchanges to the north and south.

According to the 2003 LRDP, the University will incrementally relocate its parking resources to locations peripheral to the core of the campus and easily accessed by these routes. With modifications to University Avenue, such as reconfigured freeway interchanges and enhanced sidewalks and pedestrian and bicycle paths, University Avenue can become a more pedestrian and bicycle-oriented environment. Although University Avenue will remain the logical visitor entry and primary

addressing street to the campus, regular commute traffic will be encouraged to access the campus via the other two interchanges, minimizing traffic on University Avenue.

Collaboration on future planning and development activities.

Key to the success of the concepts regarding University Avenue will be the future collaboration between the City of Riverside and the University of California. This may take a number of forms ranging from consultation and review to participation in development activities.



PLANNING CONTEXT

PLANNING CONTEXT

Existing Site Configuration

The land area addressed in this West Campus Area Plan is approximately 237 acres, and includes the area north of Martin Luther King Boulevard, generally bounded by University Avenue or Everton Place on the north, Chicago Avenue on the west, and the I-215/SR-60 freeway to the east. A secondary roadway, Iowa Avenue, bisects the site.

Existing Uses and Facilities

The majority of the West Campus land area is currently in use as agricultural research fields, mostly citrus groves. The research fields are managed by the Agricultural Operations Department of the University, and host a variety of research projects. The largest area of research fields, 295 acres, lies south of Martin Luther King Boulevard. This area will remain in agricultural research use.

Several University facilities, besides the research fields, currently occupy the West Campus. These include Parking Lot 30, accommodating 2,092 spaces, which is located directly to the west of the Canyon Crest Drive undercrossing of the freeway. University Extension (UNEX) occupies a six-story building and has an associated parking structure. It is located on the south side of University Avenue, west of the freeway. Highlander Hall, a two-story office building, is directly adjacent to the freeway, and the two-story Human Resources Building is located between Highlander Hall and UNEX. These three buildings occupy the only parcels the University owns on University Avenue. Also on the West Campus is International Village, a newer complex of 92 units of housing, intended for visiting international students undertaking studies associated with University Extension.

A City of Riverside electrical substation also occupies approximately 0.9 acres directly west of the freeway at the northern edge of Parking Lot 30. It is served by a City-owned high-voltage electrical transmission line that runs north/south and is located just west of the substation. It is assumed that the substation will remain in operation at this site, possibly with improvements such as partial or full enclosure of the facility. However, relocation of the City-owned transmission poles will be necessary for future development of the West Campus and is discussed in the Infrastructure and Utilities section of this document.

A State of California Department of Transportation (Caltrans) service yard occupies a 4.1 acre triangular parcel directly west of the freeway near the University Avenue interchange. Preliminary discussions with Caltrans have indicated their willingness to transfer this property to the University at such time as they are able to identify and move to a suitable replacement site. For that reason, it has been assumed in this plan that this parcel is included in the future development of the University on the West Campus and has been included in the total acreage figures cited previously.

The Gage Canal traverses the site north to south. A concrete-lined irrigation viaduct, the canal is now partially piped and covered. The remaining portions within the West Campus will also be covered as development of the West Campus occurs. The canal has no habitat value.



Figure 2 Existing citrus groves on the West Campus north of the Martin Luther King Boulevard



Figure 3 International Village housing, off Everton Place, provides 92 units of housing for visiting students

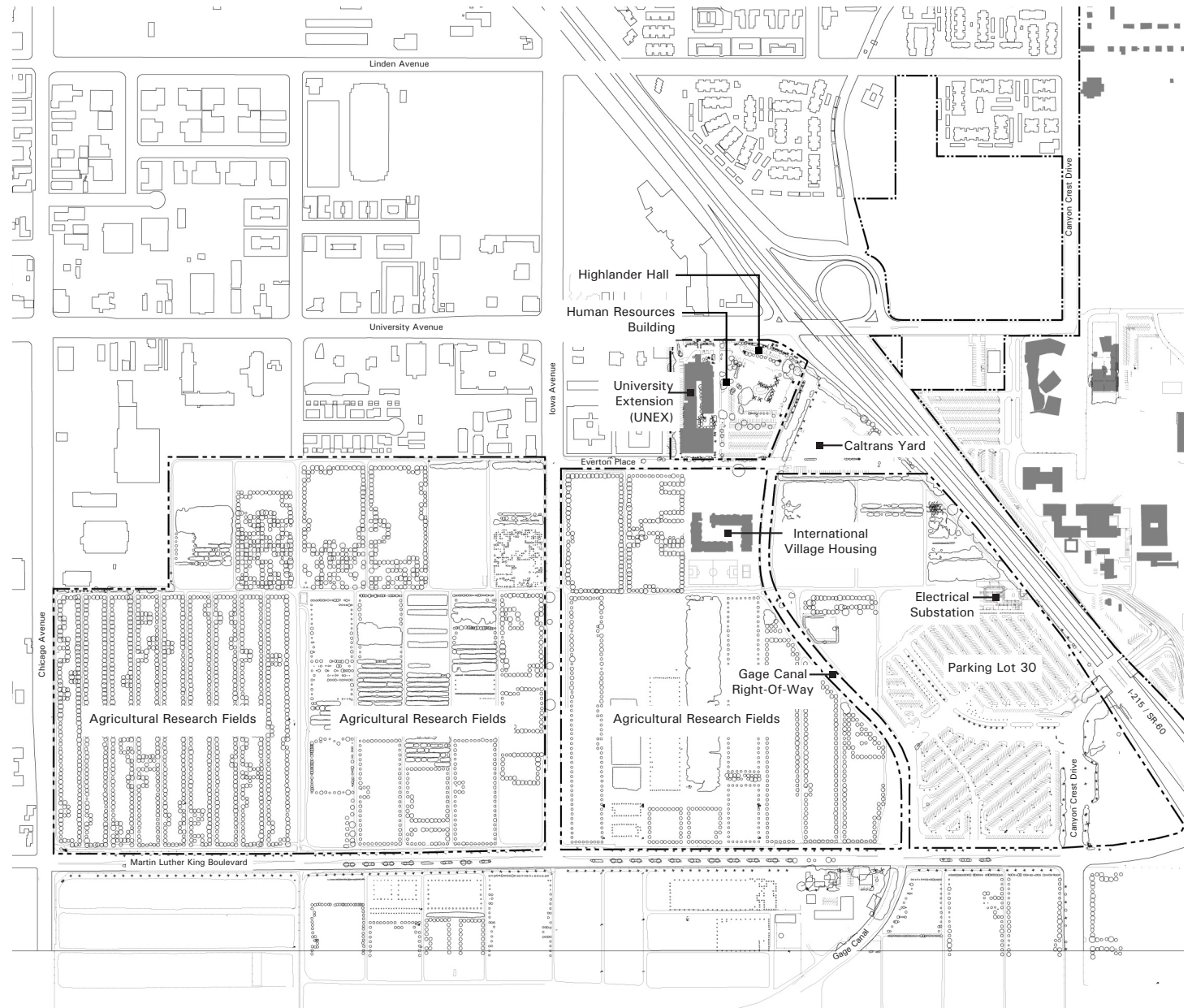

Figure 4 Parking Lot 30 (left), just west of the I-215/SR-60 freeway, looking back toward the East Campus



Figure 5 The Gage Canal (right) is largely uncovered in its right-of-way through the West Campus

Figure 6 Existing UCR West Campus facilities and uses



LEGEND

--- Campus Boundary



Existing Access

Access to the University Extension facilities is either via University Avenue or Everton Place, which connects to Iowa Avenue. Access for agricultural operations occurs via a number of unpaved and paved roads throughout the area, with entry generally through gates off one of the major roadways. Parking Lot 30, which is used primarily by students, has entries from Canyon Crest Drive and Martin Luther King Boulevard. Access to International Village is via Everton Place. The substation is entered from Parking Lot 30. Access to all of these facilities must be maintained in the future, with the exception of the teaching and research fields that will be removed over time and replaced with academic, residential, and recreational uses.

Major improvements to the I-215/SR-60 freeway will occur in the next few years. The freeway will be widened and the Martin Luther King Boulevard interchange will be expanded to allow full northbound and southbound movement, but with no direct connections to East Campus Drive, to avert cut-through traffic. As part of this project, access between the East and West Campuses will be improved with the widening of the Canyon Crest Drive underpass, installation of four travel lanes, two in each direction, and provision of an elevated, widened sidewalk and bicycle path on either side of the roadbed.

Facility Program

The 2003 LRDP identifies a facility program for the West Campus, which is shown on Table 1 and described below.

Projected Academic and Support Program

West Campus academic uses will include teaching and research facilities, administration and support. All professional schools will be located in the West Campus, which will allow them to take advantage of good visibility, easy access, and a conference/accommodation program expected in the University Extension area. Other academic uses may include program elements of any UCR college. Some administrative uses will be located on the West Campus as will public service uses.

A minor amount of student services will be on the West Campus, however, services requiring intense student contact will remain on the East Campus. Recreation fields and a satellite recreation center are also planned for the West Campus. Non-institutional uses, such as private sector/governmental/non-profit/university consortia or institutes may be desirable in the future. While no program can be predicted for these uses, they could be accommodated on the West Campus, assuming adequate space remains for UCR programs.

Projected Housing Program

The primary occupants of housing on the West Campus will be students with dependents, upperclass and graduate students. The campus as a whole has been planned in the 2003 LRDP to accommodate up to 50% of the projected student enrollment (head count) of 25,000. Of this 12,500 student on-campus population, approximately 3,501 students, or 28% of the total, will be housed on the West Campus. West Campus housing will consist of 714 units of family housing and approximately 2,787 apartments for graduate and upperclass students. No residence halls will be located in the West Campus. The unit types appropriate for families and graduate students would also be suitable for faculty and staff, if demand warrants in the future.

The residential area will also include childcare facilities. Currently childcare is provided in a facility on the East Campus off Watkins Drive, which will be expanded in the near future. However, significant unmet demand exists and will increase as the campus grows. Therefore, two new facilities are planned in proximity to family housing to accommodate an additional enrollment of approximately 300 children.

Projected Parking Program

Parking will be provided on the West Campus: commuter parking will be located in lots and structures at the edge of the academic core; residential parking will be provided within the residential neighborhoods.

Table 1 West Campus Academic and Support Facilities Program

Academic and Support Facilities Program	Gross Square Feet
Existing Facilities to Remain (UNEX, Highlander Hall, Human Resources Building, International Village)	247,800
New Program	
Academic	550,000
Professional Schools	700,000
Administration	350,000
Public Service	320,000
Non-institutional	unknown
Student Services	100,000
Total New Academic Program	2,020,000
Grand Total Academic and Support Facilities	2,267,800

Table 2 West Campus Housing Program

Residential Housing Program	Units/Beds	Parking/Student Ratio
Apartments	2,787 beds	1 space/2 students
Family Housing	714 units	1 space/student
Residence Halls	0	n/a
Total Housing Program (units /beds)	3,501	



PLAN ELEMENTS

PLAN ELEMENTS

The West Campus Area Plan consists of the following elements that are described in this section:

- Plan Influences and Themes
- Plan Framework
- Land Use
- Parcel Plan
- Circulation and Parking Plan
- Open Space Plan
- Utilities and Infrastructure

The Guidelines section that follows Plan Elements provides further detail and guidelines for site planning, building and landscape design.

Plan Influences and Themes

The West Campus Area Plan has been shaped by several themes that emerge from the history and character of the campus and region. These themes suggest physical manifestations that are appropriate to guide the layout and character of the West Campus. The themes include:

- Regional History and Character
- Ease of Connections and Grid Orientation
- Appropriate Density
- Compact Development Pattern
- Sustainability and Climate Sensitive Design

Regional History and Character

The rich agricultural history of Riverside County and UCR in citrus research and cultivation provide a unique point of reference for the design and planning of the West Campus Area.

The Riverside area saw a succession of cultures and inhabitants – indigenous groups, Spanish missions, Mexican land grants - culminating in the arrival of a significant influx of American settlers in the late 1800s. With the settlers came introduction of the navel orange and its cultivation in the region. At its height, over 12,000 acres were in cultivation in Riverside County in the early 1940s.

However, starting in the 1940s and accelerating thereafter, citrus acreage in Riverside County and throughout the region declined dramatically, as the region’s population soared. The population of the County, which stood at only 3,000 in 1883, in 1990 had reached 1,170,413, according to the U.S. Census. Less than 2,500 acres of citrus groves remain today.

In 1907 the University established a citrus experiment station at the foot of Mt. Rubidoux. In 1917, this facility was moved to the current site of UCR at the foot of the Box Spring Mountains. Later known as the Citrus Research Center and Agricultural Experiment Station, today it is a leading worldwide center for agricultural research. A college of liberal arts was opened at the Citrus Station site in 1954 with an initial class of 130 students. In 1959, it was converted to a general campus of the University of California, and has grown to an enrollment of approximately 14,000 undergraduate and graduate students in 2000-01.

The University saw rapid growth in the 1950s and 1960s, corresponding to the growth of college-age children known as the post-WWII “Baby Boom.” Many of the buildings that remain today in the academic core of the campus east of I-215/SR-60 date from this high-growth era, and exhibit the modernist design sensibilities typical of that time. The buildings of the East Campus do not display design characteristics that are particularly related to the history or heritage of the Riverside area or citrus research or the semi-arid desert region within which UCR is located. Nonetheless they establish a visually compelling institutional image for the academic institution that is based on the traditional American campus model of the tree-lined grassy malls, quads, and connecting spaces surrounded by buildings of generally uniform height, scale and bulk. In some areas such as around the Carillon Mall, some buildings are of low scale and intensity. Accommodating



Figure 7 Historic Southern California citrus crate art.

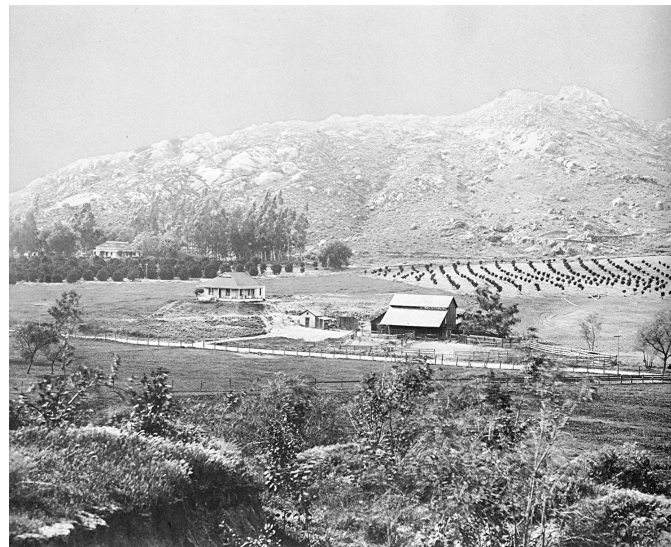

Figure 8 Citrus Experiment Station at Mt. Rubidoux in 1907.

Figure 9 The Citrus Experiment Station in 1948. The new college would occupy the area east (right) of the highway.



projected growth of the campus will require that future development be accomplished at higher than these historic intensities.

Like the surrounding county, the campus has faced pressure to convert agricultural lands to development sites. This has been successfully resisted until recently, and the 2003 LRDP continues to require significant intensification of densities in the East Campus in order to minimize the need to expand into agricultural research lands. However, with growth to a 25,000 student population, additional lands are needed and expansion into the West Campus is required. As noted earlier, the University will continue to retain over 295 acres in field research south of Martin Luther King Boulevard, the majority of this relating to citrus cultivation. The University has also acquired other research stations in the region, such as the 540-acre Coachella Valley Agricultural Research Station.

Small remnants of the history of citrus cultivation can still be found in the Riverside area. The recently-created California Citrus State Historic Park, located approximately 7-1/2 miles southwest of the campus, preserves 377 acres of citrus orchards, provides facilities for special events, and grounds for picnicking and recreation.

This rich history of citrus cultivation and research, both at UCR and in the Riverside County area, represents a resource to be treasured and recollected. It also presents opportunities for creating an important symbolic framework for the design of facilities and grounds as the University grows into the West Campus area. As described in the pages that follow, a citrus grove will be established in the West Campus as the centerpiece of the academic core. Intended to remain a permanent reminder of the rich citrus heritage, it will play a more modern role, accommodating a variety of active uses, important buildings, art, and contemplation.

Figure 10 Early planting activities at the new Citrus Experiment Station, with original buildings (now the A. Gary Anderson Graduate School of Management) in background.



Ease of Connections and Grid Orientation

Connectivity within the entirety of the UCR campus is important to allow the many activities of the campus to occur efficiently and effectively.

Two connections between the East and West Campuses currently exist and must be strengthened. University Avenue on the north, is not only an important east/west connection, but is also planned by both the campus (in the 2003 LRDP) and the City of Riverside (in An Addendum to the University Community Plan) to be a primary high intensity mixed use corridor hosting a variety of campus and community-serving uses. Canyon Crest Drive also connects the east and west areas under the freeway. With improvements at the I-215/SR-60 interchange with Martin Luther King Boulevard, this under-crossing will be widened to allow four moving lanes, bicycle lanes and widened sidewalks. The development of the West Campus must provide strong links to these points.

The pattern of development within Riverside County and as seen in the immediate vicinity of the University, is based on the original federal Land Ordinance of 1785 which placed a great grid on the entire continental landscape of the United States. This grid, based on the one-mile square sections and finer-grained half-sections and quarter-sections, is the basis of the grid of the agricultural landscape that characterizes most of California and parts of Riverside County. Throughout history it has been a powerful form-giver in the shape of open agricultural landscapes as well as in the layout of cities and towns.

The West Campus will retain a strong orthogonal grid orientation as the underlying campus framework. This will serve to minimize the visual and physical impact of the diagonally-aligned freeway right-of-way. Utilization of the grid to orient and organize roads and other connections also will help assure a convenient pedestrian and bicycle environment and good connections to University Avenue and the Riverside community. The design of Iowa Avenue to facilitate crossing movements and minimize traffic speeds will be particularly important to provide connectivity through the West Campus.

Appropriate Density

In order to assure that long-term flexibility is maintained for UCR, the 2003 LRDP has noted that all future facilities within the academic zones must be developed at densities averaging a floor area ratio of 1.0. Floor area ratio (FAR) is a measure of building density that relates square footage of site area to the gross square footage of a building. For example, a FAR of 1.0 means that for every 1,000 square feet of site there is a corresponding 1,000 square feet of building on that site (it is not an indicator of height, the square footage may be in one or multiple stories). This density of development is characteristic of the area around the Science Library; by contrast, the Carillon Mall, with some of the original UCR buildings of one and two stories, is considerably lower in density than this, at approximately .65 FAR. In the future, buildings must replicate the higher densities in order to achieve the required square footage to accommodate future needs without sacrificing important open spaces or additional agricultural research lands. Generally, this will mean that buildings will average three to five stories in height in order to allow for site landscaping, access and service areas.

Compact Development Pattern

Similar to the East Campus, academic uses will be assembled to create an academic core for the West Campus. This core will be located as close as possible to the East Campus academic core, thereby assuring optimal accessibility and reasonable walking times between the east and west academic areas. Thus, in the future, the UCR academic core will be a dense, contiguous area located on both sides of the freeway, with generally all facilities located within a ten to fifteen-minute walk from its center near the Carillon Mall.

Sustainability and Climate Sensitive Design

Sustainable design and planning is increasingly recognized as an appropriate approach in university campuses and their communities. Sustainable design principles can be applied to the full range of planning, design and operational elements of a campus. The 2003 UCR LRDP identifies plans and policies for sustainability, and the West Campus can be a demonstration of these principles.

The climate of Riverside can be hot and dry in summer and during portions of the spring and fall. Temperatures over 90 degrees Fahrenheit are common at those times. As a consequence, designing the West Campus to provide plentiful shaded, cool and protected outdoor spaces is particularly important. However, good practice for sustainable design suggests that such spaces should be provided with minimal use of scarce water resources and use of energy for irrigation and maintenance. Therefore, unlike the East Campus, which contains a highly water-intensive cultivated landscape, the West Campus will be developed to be less water and energy intensive.

In addition to providing comfortable outdoor spaces for movement and gathering, climate appropriate design will incorporate sustainable design practices to minimize energy use and ensure a comfortable interior building environment. Consideration of LEED™ criteria of the U.S.. Green Building Council or similar standards in the design of new buildings will help achieve energy efficiency as well as other benefits (see Architectural Design Guidelines in Section 5).

Plan Framework

The Plan Framework in Figure 11 illustrates the overall organizational template or framework for the West Campus. Building upon the themes noted above, the West Campus framework:

- Is based on a subdivision of the historic grid of the University the West Campus agricultural lands, and the surrounding city;
- Establishes the framework on which all land use, circulation, open space and building systems are organized;
- Establishes an academic zone east of Iowa Avenue, with a framework that allows parcels of approximately 300 feet in depth, suitable for a typical range of institutional buildings;
- Establishes a framework for residential areas, adjacent to and west of Iowa Avenue, with internal streets creating blocks of approximately 300 feet square, which is a typical urban block size conducive to pedestrian movement;
- Creates a major block measuring approximately 800 x 850 feet, approximately 15 acres, in the center of the academic area reserved for a major landscape feature and special buildings ("The Grove" - see Open Space section);
- Allows flexibility within the framework of streets and blocks; some streets will be for auto use, others will be designated as limited vehicular access or for pedestrian, bicycle and emergency/ service access only.

Figure 11 Plan Framework

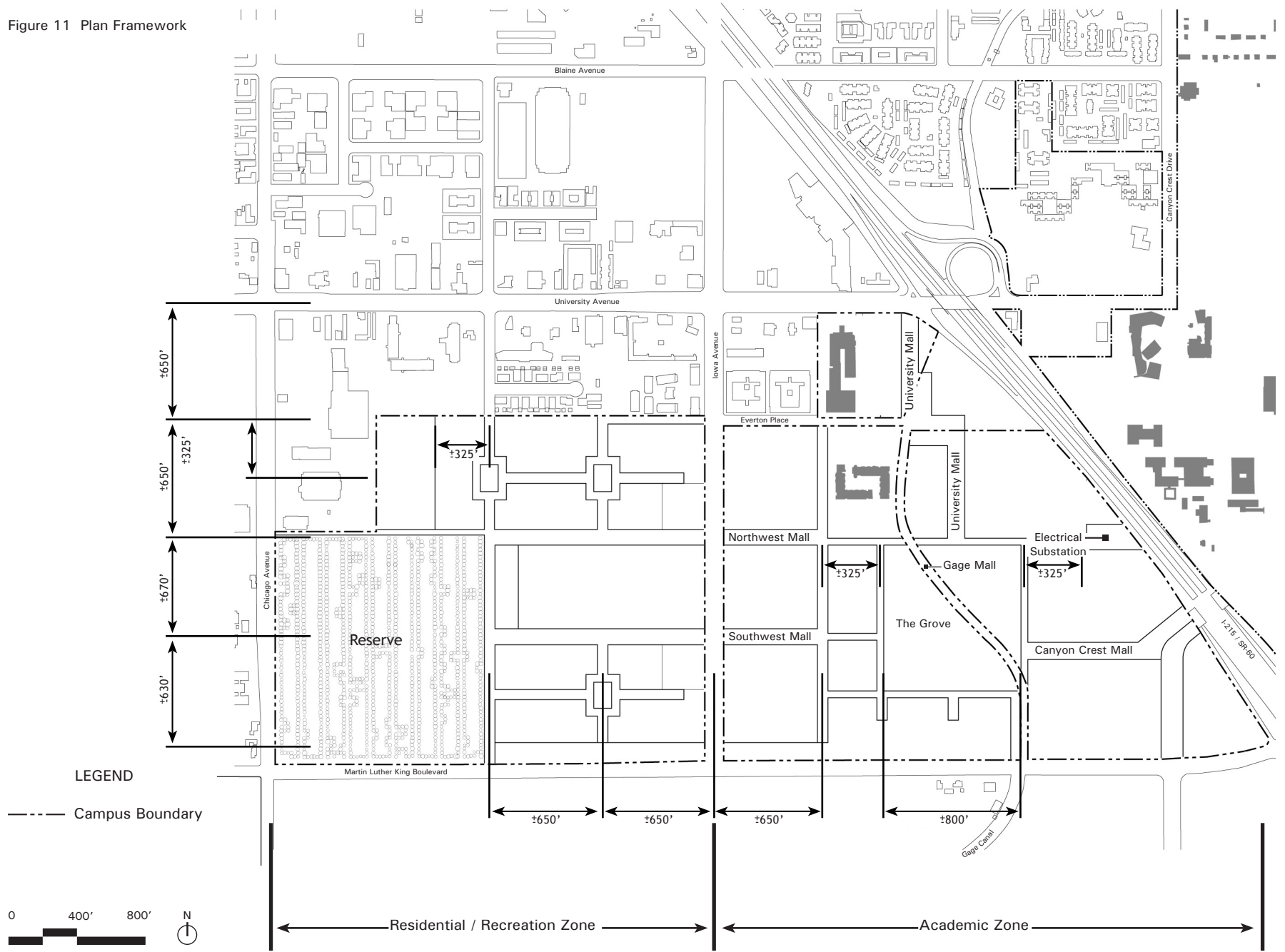

LEGEND

--- Campus Boundary



Residential / Recreation Zone

Academic Zone

Land Use

The Land Use Plan (Figure 12) indicates the planned disposition of land uses throughout the West Campus. The land uses shown correspond to the general categories of land uses identified in the program statement in the prior Facility Program section. They include:

- Academic Instruction and Research
- Professional Schools
- Administration/Non-Institutional
- Special Academic
- Public Service
- Family Housing
- Apartment Housing
- Childcare
- Open Space
- Athletics and Recreation
- Support
- Parking
- Campus Reserve

As described in the plan themes, land uses are organized on the West Campus in order to mesh well with and to complement the established pattern of development on the East Campus. Most importantly, these uses have been arranged to assure good connectivity with East Campus uses and to allow ease of access, particularly for students and faculty. By requiring future facilities to be developed in the patterns indicated at densities of at least 1.0 FAR average, the academic core in particular will have good proximity to similar East Campus uses. Table 3 summarizes the acreages and densities for each of the land uses noted above.

Following are further descriptions of the locations and arrangements of the West Campus uses:

Academic Instruction and Research

Academic uses include classrooms and lecture halls, faculty and staff offices, laboratories, and associated teaching and research support space. These uses are closely associated with other related uses including professional schools and administration. Academic uses are concentrated immediately west of the freeway adjacent to The Grove, thereby

assuring proximity to similar uses on the East Campus and a central location. Compared with professional schools, general academic uses do not need as much visibility or easy outside vehicular access. Many users will/can arrive on foot or by bicycle. Therefore, these academic parcels are not located adjacent to major roadways, but rather are located in internal areas of the West Campus.

Professional Schools

Due to its excellent visibility and accessibility, the West Campus will eventually house most, if not all, of the professional schools at UCR. Sufficient land is allocated to develop 700,000 gross square feet of professional schools at a 1.0 FAR. The professional schools are located around The Grove and along the Canyon Crest Mall (see also Open Space section). They are located to be directly accessible from Canyon Crest Drive, Martin Luther King Boulevard and Iowa Avenue. The first anticipated facility, the Professional and Graduate School Center, will likely occupy a prime location on axis with the Canyon Crest under-crossing, fronting on the Canyon Crest Mall, and easily accessible from the Martin Luther King Boulevard/I-215/SR-60 freeway interchange.

Land Use Categories	AREA (ACRES)
Academic - Academic Instruction & Research	11.3 AC
Academic - Professional Schools	17.3 AC
Academic - Public Service	6.0 AC
Academic - Administration / Non-Institutional	14.6 AC
Special Academic Building Area	8.2 AC
Family Housing	24.2 AC
Apartment Housing	39.1 AC
Childcare	3.0 AC
Open Space	44.5 AC
Athletics / Recreation	14.1 AC
Support	8.9 AC
Parking	8.3 AC
Campus Reserve	37.3 AC
Total	236.8 AC*

*Including sites currently not owned by the University of California, Riverside. Caltrans Yard, and Gage Canal.

Table 3 West Campus Land Use Acreages

Figure 12 Land Use Plan

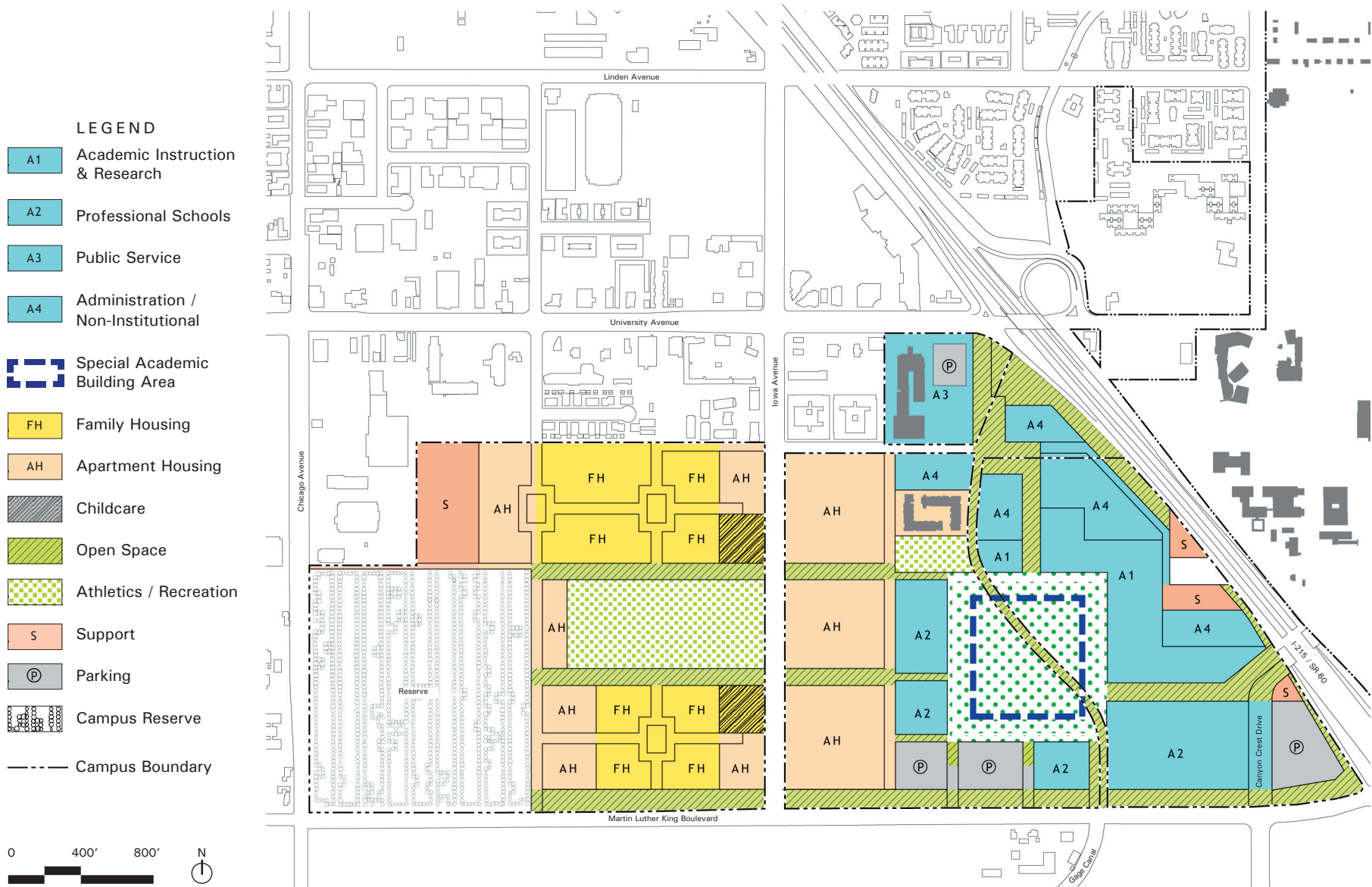

Administration/Non-Institutional

The West Campus will accommodate some administrative uses, although these are unlikely to be of a type requiring high levels of student or public interaction. They have been located, therefore, behind the primary academic uses which front on the highest areas of pedestrian activity.

These administrative areas are also suitable for non-institutional users and potential partners of the University, such as private research companies and institutes, since these uses also would not require high levels of student or public interaction.

Public Service

Uses such as a conference center and University Extension require excellent public visibility and good accessibility for visitors. As a consequence, these uses are located along University Avenue and near the freeway, and adjacent to the existing University Extension facilities. It is planned that this complex will be partially redeveloped for more intensive use, possibly including a conference center and hotel. As part of this redevelopment, Highlander Hall, a modest one- and two-story former motel, will be removed. The existing 6-story University Extension and its parking structure are expected to remain.

The hotel wing of a conference/hotel complex could be located adjacent to University Avenue to assure visibility, which would make it more attractive to a third-party developer, and which would allow easy public access as well. A new parking structure to provide additional parking for the conference center, hotel and general university use would also be developed as part of the overall redevelopment of the site. Active ground floor uses on University Avenue in the hotel wing would help in the revitalization of University Avenue and act as a magnet to pedestrians crossing under the underpass (see Design Guidelines).

Family Housing

Family housing is located west of Iowa Avenue. Neighborhood parks and children's tot lots will provide amenities in this zone. Family housing areas are planned at an approximate net density of 30 dwelling units per acre (subtracting the neighborhood parks that provide

consolidated open space for the neighborhoods). It is envisioned that family housing will be of two general types: townhouses with 2-3 bedrooms per unit, and stacked flats with 1-3 bedrooms per unit. All units will have direct street frontage (see Design Guidelines).

Apartment Housing

Apartment housing is predominantly located east of Iowa Avenue, adjacent to the academic zone. Apartment neighborhoods are planned at net densities of approximately 120 beds per acre; apartments will typically contain a mix of 3 and 4 single occupancy bedroom units. Amenities will include community rooms, swimming pools, and other recreation facilities. A limited amount of student services and food service may also be located in proximity to the apartments.

Childcare

Childcare will be located in the residential area so as to be easily accessible from family housing. Two sites of approximately 3 acres each are located immediately west of Iowa Avenue. These sites each will accommodate 144 - 150 children. Facilities will be sized at approximately 13,000 square feet, housing indoor space such as offices; infant, toddler, and pre-school rooms; community and multipurpose rooms; kitchen, and storage. Outdoor play space will also be provided, at 75 square feet per child, meeting or exceeding state standards. Off street parking and drop-off areas would also be provided.

Open Space

Open space areas are shown on the plan and include the landmark open space that will be the major focus of West Campus identity (The Grove), malls, neighborhood parks. These are described further in the Open Space section of this report.

Recreation

Intramural fields will be the predominant type of athletics/recreational space provided on the West Campus. The fields have been located to be within easy access of the apartment and family housing areas. In addition, a 50,000 - 60,000 square foot recreation center and swimming pool will be provided on the West Campus. Lighting will be provided for nighttime use and for security.

Support

As the West Campus grows it will be important to have adequate support facilities for efficient operations of campus maintenance, receiving and other operations. Should expansion or relocation of the Environmental Health and Safety facilities not be feasible on the East Campus, they can be relocated to the Support area on the West Campus.

Support facilities are expected to include:

Central Plant

As discussed in the Utilities and Infrastructure section of this report, future central plant facilities will be provided either 1) integral to future buildings, 2) in small distributed plants adjacent to clusters of buildings, or 3) in one or two larger consolidated plants, with the ultimate need being determined by the nature of future building development and phasing. Space for a consolidated central plant is provided adjacent to the electrical substation near the freeway. Adequate site space also exists within the academic zone for smaller distributed facilities if warranted.

Physical Plant

An area of about 5 acres is provided on the West Campus, off Chicago Avenue, for expansion of the East Campus Physical Plant facilities. Uses that might relocate to the West Campus include central receiving, campus fleet, shuttle bus maintenance and storage.

Transportation and Parking Services (TAPS)

A small site is identified adjacent to the undercrossing of Canyon Crest Drive and the freeway at Canyon Crest Mall. This site would be a suitable location for TAPS or other support services since it is accessible by auto, transit or by foot, is directly adjacent to a major campus entry, and is centrally located within the overall east-west campus core.

Parking

Four commuter parking sites are located at the periphery of the academic zone. It is envisioned that over time most of these locations will be developed as structures. A small amount of surface parking will be distributed throughout

the academic zone for the disabled, service and special permits. Parking for residential units is provided in on-site lots and by means of on-street parking.

Campus Reserve

An area of approximately 40 acres at the most westerly end of the West Campus, at Chicago Avenue and Martin Luther King Boulevard, is set aside as a Campus Reserve. No uses are currently envisioned for this site. In order to retain long-term program flexibility, this area will not be available for development in the foreseeable future and will remain in citrus and agricultural cultivation. Any change in the current use of these lands will be determined at such time as future additional program requirements have been identified.

Parcel Plan

The Parcel Plan (Figure 13) illustrates the parcel pattern that will accommodate the range of academic uses described on the Land Use Plan, while also allowing adequate space for service, access and open space.

Parcels indicated are intended as a guide to assist in siting facilities of various sizes. Overall, academic uses must be developed at an average FAR of 1.0. Developing at a lesser density may result in inadequate availability of land in the future. Generally, parcels are sized at slightly larger than one acre. This allows parcels to support development of buildings of approximately 50,000 square feet at an FAR of 1.0. Larger building program needs can be accommodated by combining two or more parcels, as illustrated in the Design Guidelines. Parcels should not be reconfigured to encroach upon major designated open spaces or other major land use types.

The special academic uses targeted for The Grove occupy a special parcel. In this location, a general development zone is identified, set in 100 feet from the edge of The Grove at the Grove Frame. Within the area defined by this setback, special academic buildings may be located. As noted in the Architectural Guidelines section of this report, the intention is not that buildings would fill The Grove, but rather that they would be clustered within the larger fabric of groves of trees, joined by complementary uses such as art and display gardens, and special event venues.

Figure 13 Parcel Plan

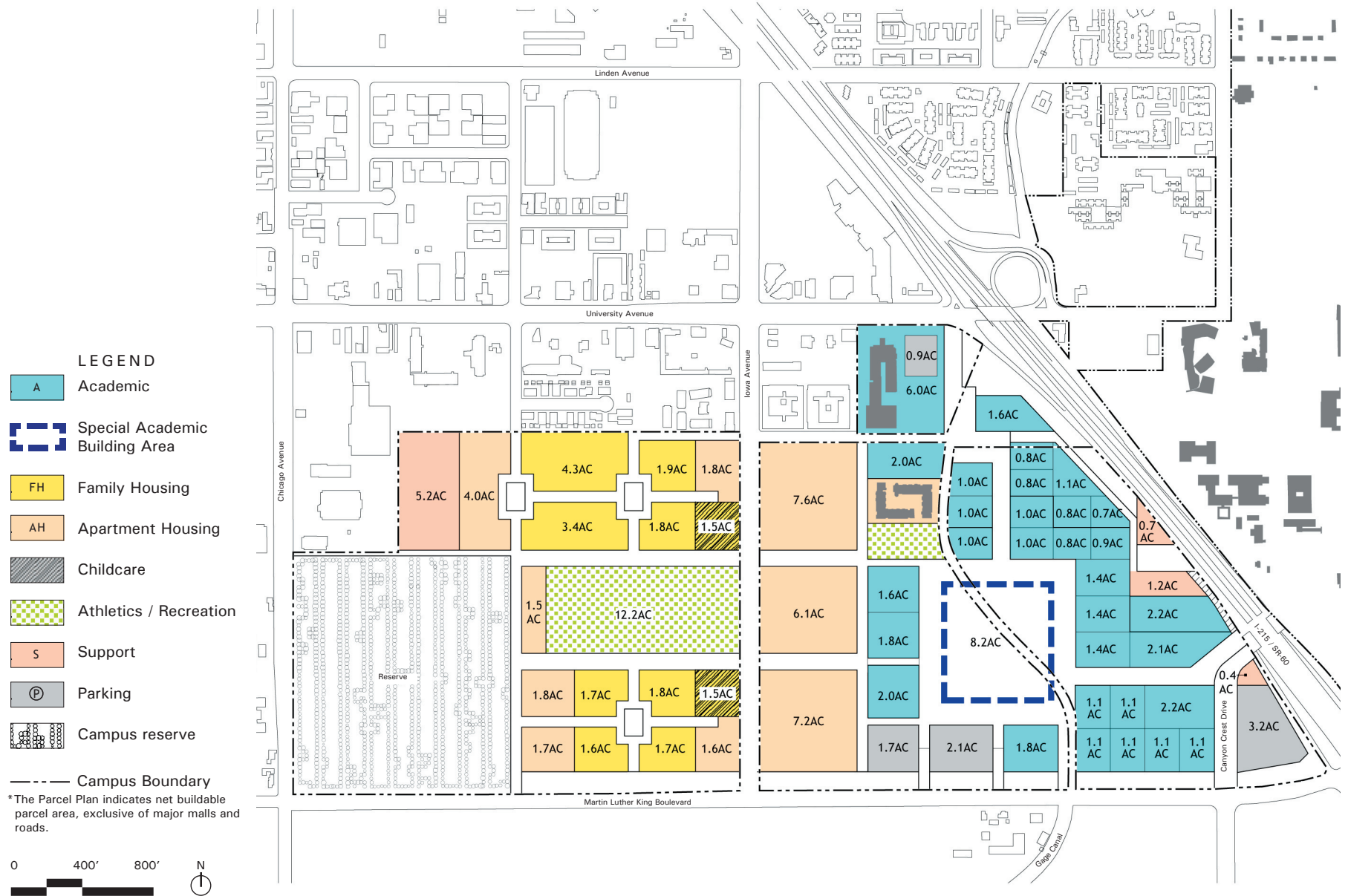

*The Parcel Plan indicates net buildable parcel area, exclusive of major malls and roads.

Circulation and Parking Plan

Vehicular Circulation

In order to promote a pedestrian-friendly campus with convenient access for faculty, students, staff and visitors, and to encourage bicycle and transit use, the West Campus is organized with a high density, pedestrian-oriented academic core area that has strictly limited vehicular access. The residential street layout for the West Campus has been planned to discourage through traffic and encourage walking and bicycling.

The Vehicular Circulation and Parking Plan (Figure 14) indicates the relative size and importance of the vehicular roadways serving the West Campus. (See also Landscape Guidelines).

Primary Circulation

The primary circulation system includes three major roadways that surround the West Campus site:

- Martin Luther King Boulevard
- University Avenue
- Chicago Avenue

These three streets support regional circulation; both Martin Luther King Boulevard and University Avenue have direct freeway access and also provide direct campus access. They are designed to carry high volumes of traffic at peak hours and generally operate with good efficiencies. Although University Avenue is served by a freeway interchange, it is envisioned in both the 2003 LRDP and An Addendum to the University Community Plan that University Avenue will have a more “Main Street” character, with a priority for pedestrians and bicycles, and with frequent, safe crossings.

Secondary Circulation

The secondary circulation system includes streets that provide access to and into the campus but have less regional importance than the primary system. Secondary roads include:

- Iowa Avenue
- Canyon Crest Drive

Canyon Crest Drive will retain its current configuration except where it passes beneath the freeway, where it will be widened to provide two vehicular lanes in either direction, improved bicycle lanes and widened sidewalks as part of the Caltrans freeway interchange improvements scheduled to be completed in the next few years. It is also planned to have additional turning lanes at the intersection with Martin Luther King Boulevard. Traffic projections by the University, however, do not suggest that all the lanes currently planned at Martin Luther King Boulevard are required, and pedestrian crossing movements would be optimized if the Canyon Crest Drive cross section is as narrow as possible at this intersection.

Iowa Avenue is currently largely unimproved, except near University Avenue, where it has curbs and gutters and is wider than further to the south. In order to ensure that Iowa Avenue is a visual amenity and does not become a barrier to pedestrian movement, while allowing access to sites in the West Campus, the University has proposed that Iowa Avenue be limited to two travel lanes (one in each direction) with left turn pockets and a median. Bicycle lanes would also be provided. Traffic controls (signs and signals), corner extensions, landscaping, medians, and other improvements, as illustrated in street sections provided in the Landscape Guidelines section, will help to calm traffic and ensure pedestrian safety.

Local Access - Unrestricted

Unrestricted local access streets within the West Campus are primarily within and adjacent to the residential areas. These streets are generally designed to not connect to the major arterials (Chicago Avenue and Martin Luther King Boulevard) in order to discourage cut through and speeding traffic. They are also designed to be narrow and to allow parking in some locations, which will also serve to calm traffic.

Local Access – Restricted (no general traffic)

Restricted local access streets are intended for infrequent use by service and emergency vehicles. These routes include dedicated service roads as well as pedestrian corridors in high activity areas of the campus. Restricted local access routes will be aligned to allow easy access to all facilities on campus, but will likely be controlled through gates and signage to keep general traffic out.

Figure 14 Vehicular Circulation and Parking Plan

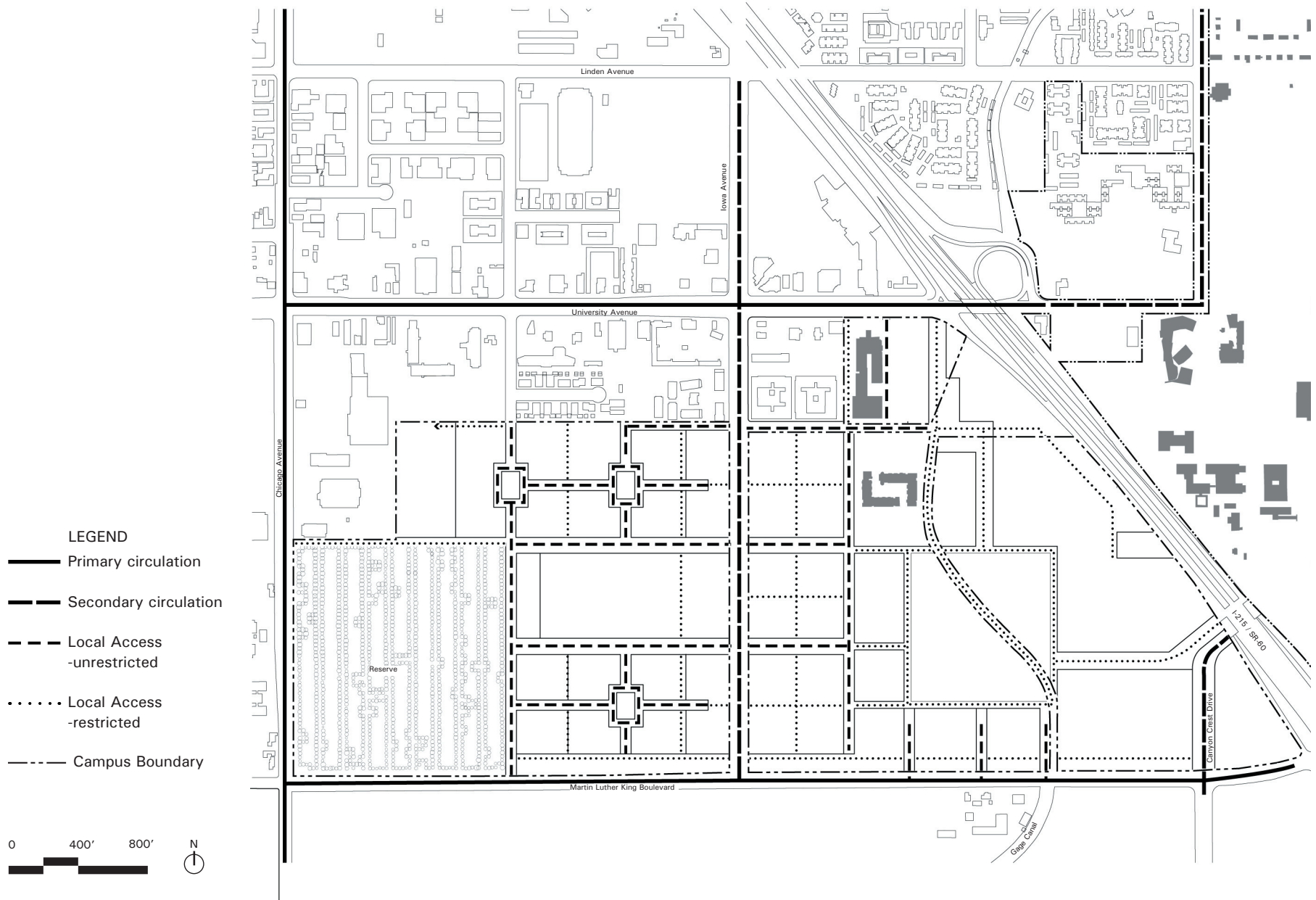

Bicycle Circulation

Bicycle use will be encouraged and facilitated throughout the West Campus area. Figure 15 delineates the bicycle circulation plan.

Gage Canal, which is currently uncovered in some areas, will be covered as the West Campus develops. When fully covered, it will become part of a citywide bicycle and pedestrian trail system that extends to the south.

Dedicated, striped bicycle lanes will be provided on primary and secondary streets, where there is significant traffic, and where there is adequate roadway width. Bicycles will be allowed unlimited access to all local access streets throughout the West Campus, where there is less traffic and slower speeds.

Bicycles will be allowed within the automobile-free zones of the academic core on the malls and connectors. Over time, as pedestrian activity increases, it may be necessary to restrict bicycle access to create bicycle caution zones, where pedestrians will have the right-of-way and bicycles must be walked or ridden with caution in limited areas. As the campus grows, bicycle plans should be prepared and updated regularly as part of overall transportation planning.

Bicycle parking will be provided throughout the academic core convenient to all major facilities. Bicycle parking will be provided within all residential building complexes.

Figure 15 Bicycle Circulation Plan

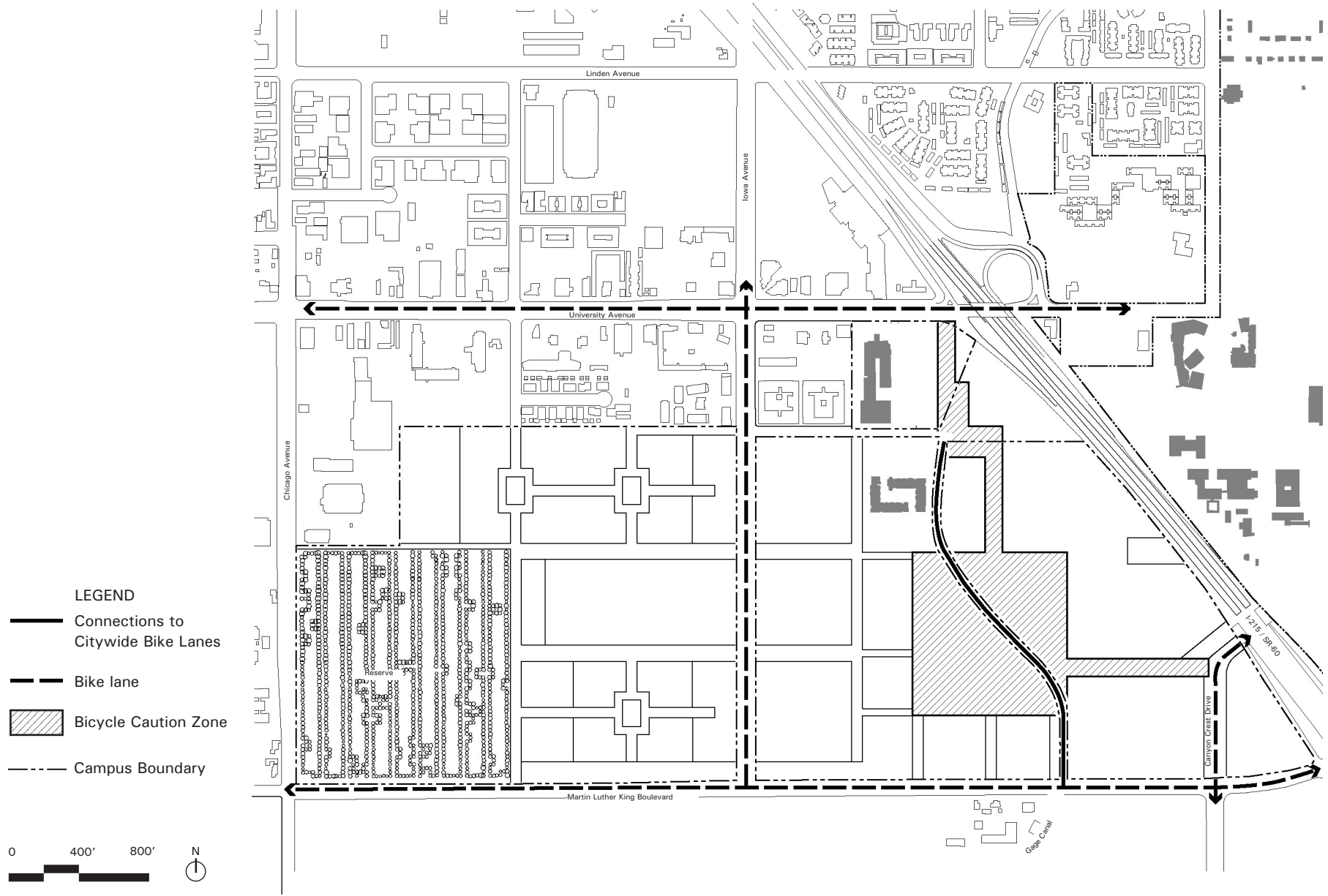

Transit Circulation

The West Campus will be served by enhanced shuttle and transit service coordinated with service for the East Campus and the Riverside Area Transit District (RTA). Campus-operated shuttles will connect many destinations throughout the UCR campus and will connect with regional transit operating on major peripheral roadways.

Figure 16 indicates streets and corridors suitable for shuttle operation. The diagram is not intended to indicate specific transit routes, which must be determined through detailed route planning with campus and regional transit planners. It will also be necessary to phase in shuttle service and adjust transit routes over time as the West Campus grows.

The shuttle corridors provide convenient access to riders originating from the residential areas and parking facilities of the West Campus. The routes have been aligned to conveniently serve high activity destinations. They will also connect conveniently and should allow reasonable trip times to East Campus destinations.

Figure 16 Transit Circulation Plan

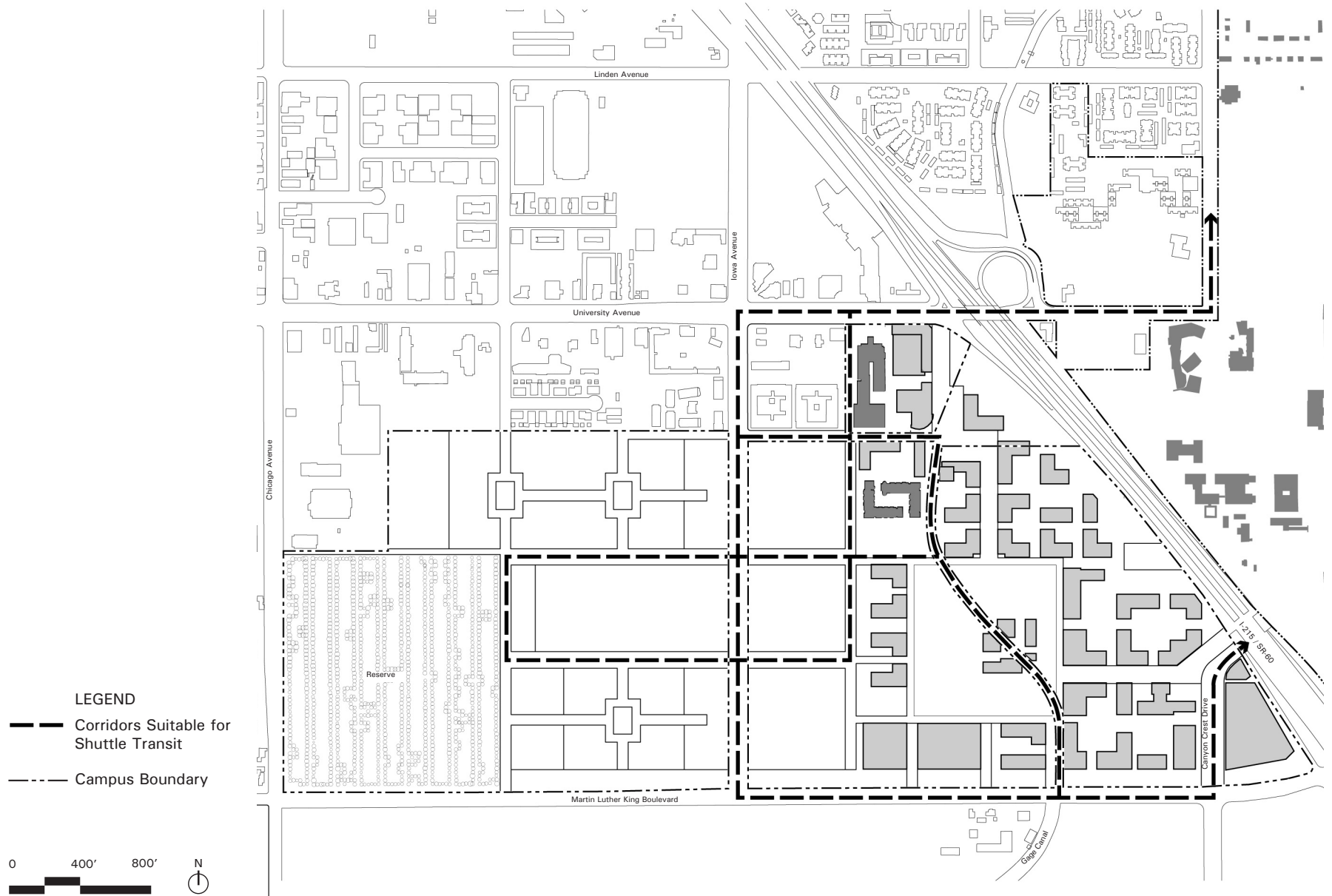

Parking

As the West Campus develops, commuter parking will be phased out of the existing location at Lot 30 into new lots and structures located more peripheral to the core of the academic area.

According to the 2003 LRDP, it is estimated that approximately 2,835 commuter parking spaces must be provided on the West Campus. This includes parking for commuters destined for the West Campus facilities, as well as for the East Campus. Three major sites and one smaller site are identified. In addition, an adequate amount of parking will be provided near buildings for disabled, special permit, and service parking. These spaces will generally be accessed via access-controlled streets and corridors as discussed in the Vehicular Circulation section.

A logical first site for a parking structure lies immediately adjacent to the freeway at the intersection of Canyon Crest Drive and Martin Luther King Boulevard. This triangular parcel will accommodate approximately 1,280 cars in four levels. A parking structure in this location is well placed to serve both the East Campus and the West Campus. It will also help block freeway noise and views. It is planned that visitor information will continue to be provided in this location, as this will remain an important visitor entry to UCR. This structure, or a small building immediately adjacent can also accommodate the needs of Transportation and Parking Services (TAPS).

The second major parking location is planned adjacent to Martin Luther King Boulevard approximately ½ mile to the west of Canyon Crest Drive. This site will accommodate approximately 1,520 cars in four levels, and can be configured in two structures. This site provides good access for commuters with destinations in the academic core of the West Campus. Direct access to this parking would be available from Martin Luther King Boulevard and the new local access road that borders the west edge of the academic core area.

The third primary parking location is associated with University Extension and could be a component of an expanded Extension/Conference/Hotel facility.

Approximately 300 cars can be parked here in three levels. A parking structure at this location should be well integrated within this mixed use complex and not front directly on University Avenue or University Mall.

Parking for residential uses will be provided within the neighborhood blocks and on the adjacent streets. For family housing a parking ratio of one space per unit/student will be provided. For apartments a parking ratio of one space for every two students will be provided. In both cases some parking will be provided on street, with the remainder in small lots located throughout the neighborhood or under buildings.

Figure 17 Parking Plan

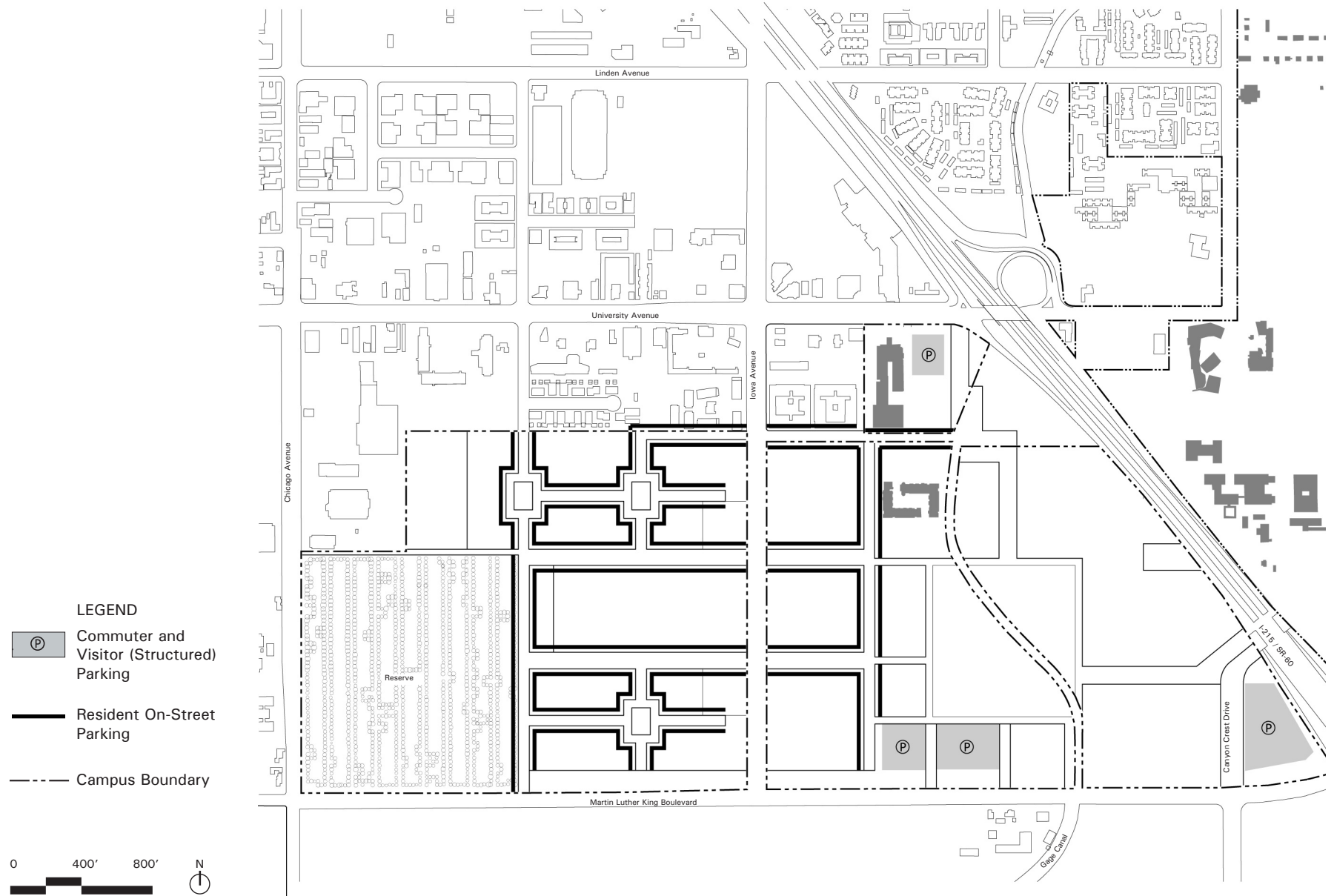

Service and Emergency Access

Convenient service access will be provided throughout the West Campus, with particular attention to the sometimes intense service needs of various academic buildings. Service vehicles of various types will need to have access to all buildings of the West Campus.

Primary service and emergency access routes are planned to accommodate heavy service vehicles such as large refuse trucks and tractor-trailer vehicles that may occasionally be required. These routes and related service courts are illustrated in Figure 18. These service routes are planned to avoid major pedestrian activity areas, the Grove and Malls. Primary service routes are generally configured to be distinct from pedestrian and bicycle routes and to intersect or coincide with them as infrequently as possible. Where feasible, service routes are planned to cross major pedestrian open spaces, corridors and promenades, rather than running parallel with them. Building service bays and courts will be provided away from major entries or other high activity zones. Wherever possible, service bays should be shared among neighboring facilities and screened.

Physical Plant pickup trucks and small maintenance vehicles will have access to all areas of the campus and will be allowed to travel on all streets and pedestrian corridors. However, pedestrians and bicycles will retain the right-of-way in these circumstances.



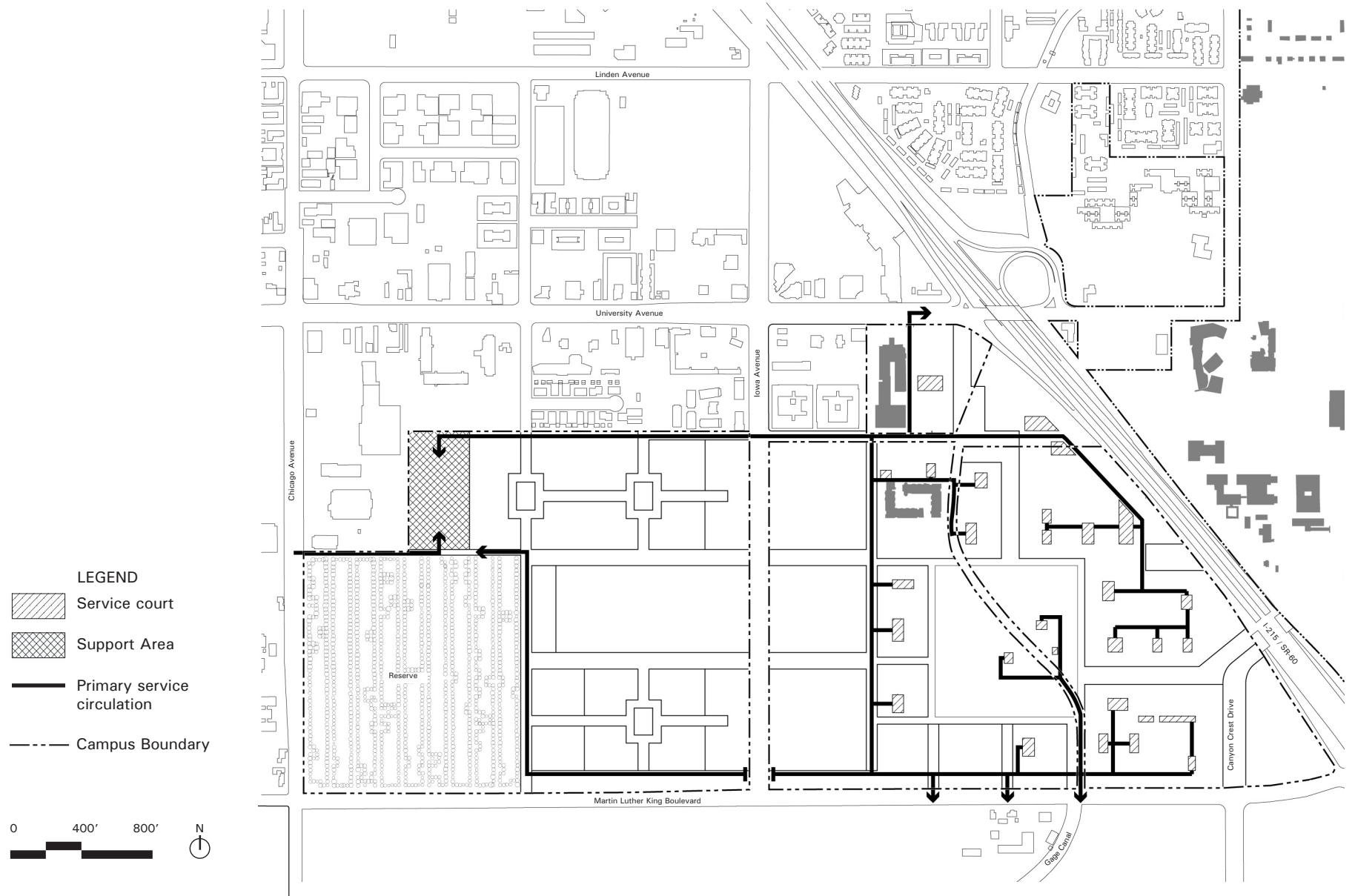

Emergency vehicles will also have access to all streets and pedestrian/bicycle corridors. All facilities will be sited to assure that clearances are adequate for fire equipment and that emergency access is clear and unimpeded.

Since the Gage Canal corridor is an important bicycle and pedestrian routes, service vehicle access will be limited, particularly in The Grove.

Figure 18 Service and Emergency Access Plan



LEGEND

-  Service court
-  Support Area
-  Primary service circulation
-  Campus Boundary



Open Space Plan

Open space and landscape at UCR play a significant role in defining the character and quality of the campus. The open space system, combined with the street and pedestrian circulation system will be a major element that provides structure to the West Campus plan. The open space system will create a linked fabric of outdoor rooms and spaces connecting all areas of the West Campus.

The West Campus open space system includes the following components:

- The Grove
- Malls and Linear Open Space
- Neighborhood Parks

The framework of major open spaces and landscaped areas for the West Campus are planned to achieve several goals:

- Express the citrus/agricultural heritage of the University and Riverside County
- Unify the campus
- Provide shade
- Protect and enhance sensitive natural resources
- Provide a variety of outdoor environments for work, study, and leisure activities
- Provide an attractive setting for University facilities that is sensitive to the existing site
- Provide functional connections for pedestrians and bicyclists

Following is a description of the major elements of the West Campus open space system.

Figure 19 Open Space Plan

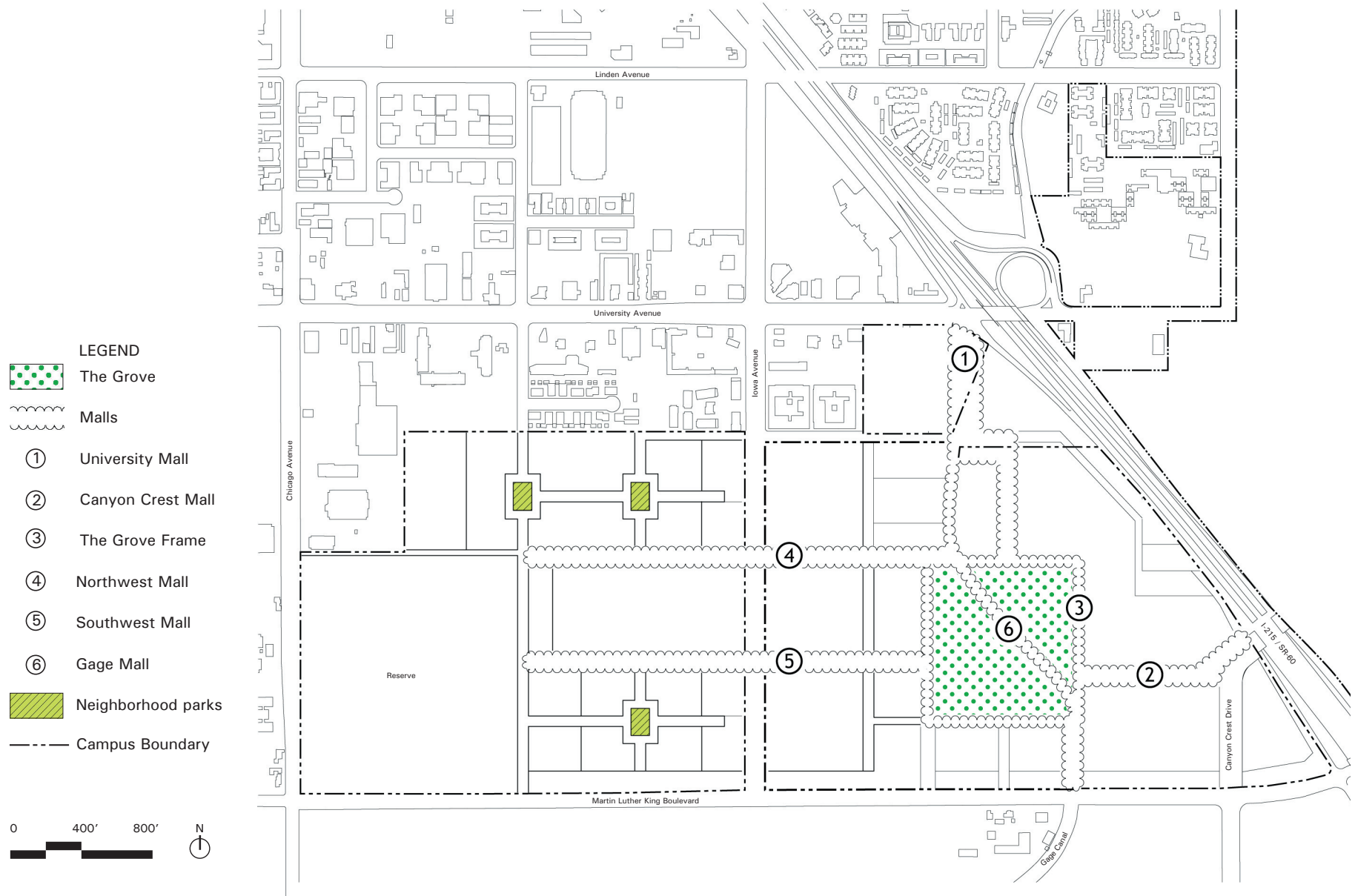

The Grove

The Grove is the primary open space and image-giving feature of the West Campus. It is approximately 15 acres in size and lies at the center of the academic area. It will function both as the landmark open space of the West Campus, as the Carillon Mall does on the East Campus, but will also accommodate important, special buildings and activities.

The planted portions of The Grove will include citrus trees as a reminder of the ongoing and historic importance of citrus cultivation and research to the campus and to the Riverside region, but will not be limited to this tree type. Trees of all kinds will be selected and maintained to assure the upright growth and high branching needed to allow vistas throughout. Plantings may be selected to create areas for educational purposes, with historic, horticultural or botanical value and interest.

Development of buildings, art and outdoor facilities will occur within The Grove. Buildings must have a unique and symbolic role for the campus as a whole and be significant destinations and generators of activity.

The Grove will be the symbolic heart of the West Campus and over time will become an important image for UCR as a whole, representing the history, present and future of citrus cultivation and biotech research in the Riverside area. The groves of trees, recalling the vast orchards that once dominated the Riverside county area and the early UCR campus, will contrast with the character of the East Campus which is dominated by the wide, often grassy malls that were built in the 1950s and 1960s and that are commonly found on University campuses throughout the U.S. The Grove represents an opportunity for the University to enhance its physical image and in so doing to distinguish itself from many other institutions by capitalizing on its research history as well as the social and cultural history of the region.



Figure 20 The Grove will include special academic buildings, such as a gallery or student center, as well as paths and areas for passive recreation.



Figure 21 The Grove may include special demonstration gardens and public art.

Figure 22 Canyon Crest Mall (looking west from near Canyon Crest undercrossing) is a major West Campus corridor and link to the East Campus. University Mall would have a similar configuration.



Figure 23 The Grove Frame consists of a wide pedestrian walkway bordering The Grove, serving as the address for academic buildings.



Malls

Malls are important open spaces in the West Campus as in the East Campus, and are both linear movement corridors and major components of the open space system. They provide an interconnected system of open spaces throughout the West Campus and are planned to provide direct linkages to the institutional core of the West Campus at The Grove from the East Campus, and from the north and west. There are six major new malls planned for the West Campus.

University Mall

This mall will be an essential component of the open space and circulation system between the East Campus and the northern portion of the West Campus, and will extend south from University Avenue to The Grove. It will also provide an important address for future West Campus buildings.

Canyon Crest Mall

Extending west from the Canyon Crest undercrossing of the I-215/SR-60 freeway to The Grove, this mall will also provide an important open space and circulation linkage between the East Campus and the West Campus.

The Grove Frame

Surrounding The Grove on all four sides is the Grove Frame, pedestrian malls linking all buildings that front The Grove. The Grove Frame also links University Mall, Canyon Crest Mall and the residential areas to the west.

Northwest Mall and Southwest Mall

These malls link the heart of the academic campus at The Grove with the family residential areas to the west. They are designed to have a wide landscaped median that will be visually attractive and serve as part of the campus storm water drainage and detention system.

Gage Canal Mall

Gage Canal Mall will be located in the right of way of the existing Gage Canal. The canal will be replaced with large diameter pipes for irrigation water and covered as development proceeds on the West Campus. The mall provides a convenient connection through the West Campus and The Grove, and connects on the south to the regional bicycle network.

Neighborhood Parks and Tot Lots

Three new neighborhood parks will be located on the West Campus. They will be sited within the family housing areas to ensure the availability of usable park space for residents within close proximity to their homes. Surrounded by narrow local access streets, they will be easily and safely accessible from the surrounding housing.

In addition to the larger neighborhood parks, areas for very small children (tot lots) will be provided on site within the family housing complexes.

It is also expected that the apartment housing will have additional amenities such as fitness facilities, pools, basketball courts and usable outdoor space.

Other Open Space and Landscape Features

In addition to the major open space system that provides structure to the West Campus, other landscaped areas and features are an important part of the image and function of the campus. These include:

- Buffer planting areas
- Gateway features
- Street landscaping
- Gardens and courtyards associated with individual buildings.

For the purposes of this discussion, these areas are not considered to be part of the major open space system of the campus. However, the character of their design is important to the overall function and image of the campus. The design of these areas and features is discussed in the Landscape Design Guidelines section.



Figure 24 Gage Mall is a high activity pedestrian and bicycle route through The Grove.

Utilities and Infrastructure

This section of the Area Plan addresses planning for West Campus infrastructure and utilities. The actual build-out of these facilities will primarily occur on a project-by-project basis to meet the rate of growth for the West Campus and to minimize up-front capital costs. See the Development Strategy section for a discussion of possible phasing of improvements to the West Campus.

Sewer

The City of Riverside Regional Water Quality Control Plant (RRWQCP) provides treatment for all campus-generated wastewater and will also treat wastewater from the West Campus Area. UCR will operate its own collection system. The RRWQCP currently treats 32 million gallons per day (MGD) and has a capacity of 40 MGD. The City of Riverside has indicated that they do not anticipate any problems in accommodating future UCR growth.

Existing West Campus System

The West Campus primarily consists of agricultural land, and has only two existing sewer lines. One line services the International Village housing complex. This line is City owned and gravity flows west on Everton Place and north on Iowa Avenue connecting to the University Avenue trunk line. The other line is University owned and services an agricultural operations building south of Martin Luther King Boulevard near the Gage Canal. This line gravity flows west in the south shoulder of Martin Luther King Boulevard and turns north on Chicago Avenue connecting to a City sewer line extending approximately 1,300 feet north to the University Avenue trunk line. The UNEX, Highlander Hall and the Human Resources Building are serviced from sewer laterals extending to the trunk line in University Avenue. Existing sewer discharge from the West Campus is less than 100,000 gallons per day (gpd).

Proposed System

The planned gravity flow West Campus sewer system is shown in Figure 25, with related catchment zones illustrated in Figure 26. In the south portion of the West Campus, new University housing and academic buildings will utilize the existing University-owned sewer line on

the south side of Martin Luther King Boulevard. The development to the north will use the existing City-owned line in Everton Place and four new lines connecting to the University Avenue trunk line. This approach provides UCR with maximum flexibility and minimum capital costs during initial phases of development.

If the capacity of the University Avenue sewer is a problem in the future, flow in that existing sewer system can be diverted at the intersection of Chicago and Martin Luther King Boulevard in a new line, which would connect 1/4 mile to the south to an existing main outfall sewer.

West Campus sewer flows were developed by applying a factor of 90% times the projected sustainable domestic water use detailed in the water section of this report. The future domestic water use is estimated to be 499,530 gpd (see Proposed Water Demand section of this report). Applying a 90% factor to the future domestic water use ($499,530 \times 0.9 = 449,577$ gpd) determines the future sewer discharge on the West Campus to be approximately 0.45 MGD.

Figure 25 Sewer System Plan

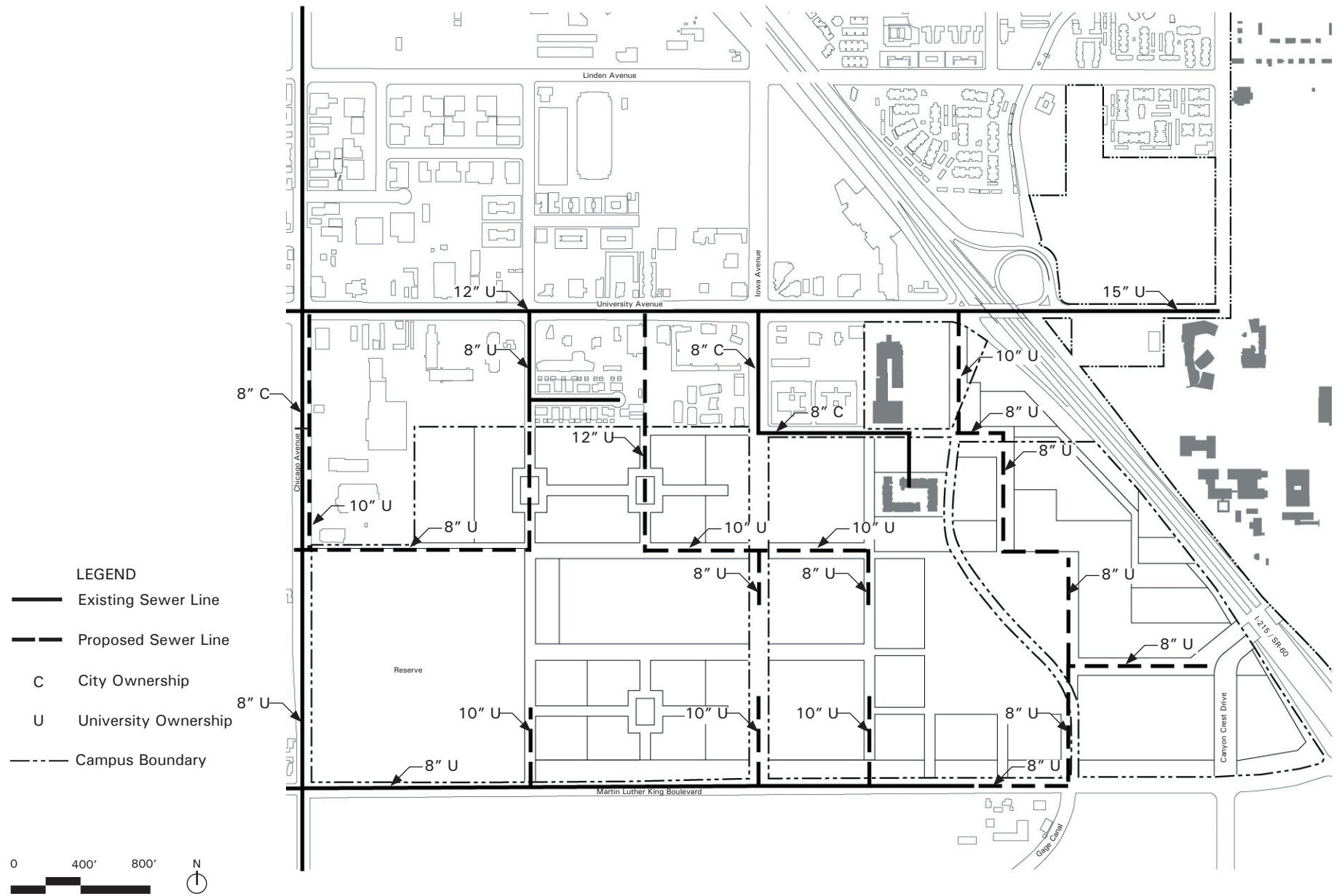
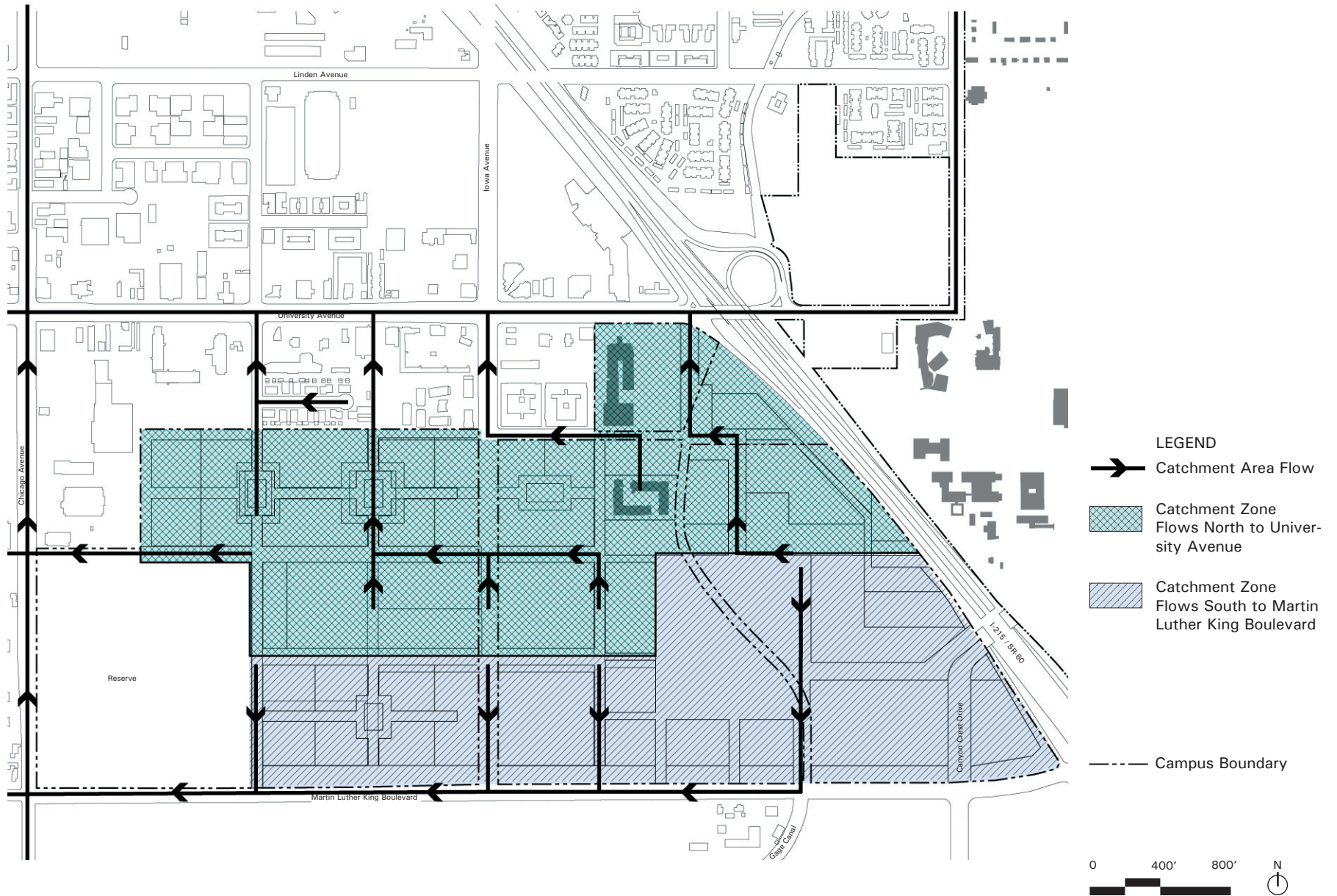

Figure 26 Sewer Catchment Zones



Storm Drainage

The Riverside County Flood Control and Water Conservation District (RCFCWC) in conjunction with the City of Riverside Public Works Department, is responsible for flood control projects within the City. UCR is divided into two watersheds on the east and west sides of Interstate 215. The West Campus is located in the Box Springs Arroyo drainage basin.

Existing West Campus

The West Campus currently consists of agricultural land used for agricultural research. The UCR West Campus storm drain infrastructure is undeveloped with the exception of two existing RCFCWC storm drains. One is a 42-inch drain pipe in the north-south Cranford Avenue street alignment which discharges into the second line. The second line is an east-west running 66-inch pipe in Martin Luther King Boulevard that flows to the west discharging into the Kansas Street Retention Basin.

Proposed Storm Drainage

The proposed West Campus storm drain system will be a gravity conveyance system that generally consists of overland flows to the south and localized storm drain systems installed with each phase that discharge into ornamental drainage swales located in the median strips of east-west running streets. The shallow, ornamental drainage swales will be interconnected for eventual connection to a north-south collection pipe that will provide controlled discharges to the existing storm drain.

The RCFCWC states that newly developed storm water infrastructure shall contain a 100-year storm event using a combination of the storm drain system capacity and the overflow volume inside street right-of-ways. In addition, a 10-year storm event discharge cannot exceed the design capacity of existing storm drain lines. Thus, the storm drain discharge generated from the West Campus during a 10-year storm event at full development cannot exceed the existing design capacity in the Martin Luther King Boulevard storm drain pipe at the intersection of Chicago Avenue. The existing design capacity at this intersection available to the West Campus is 169 cubic feet per second (cfs). Following the criteria set fourth for by the RCFCWCD

Hydrology Manual, the Rational Method ($Q = CiA$) was applied in calculating the West Campus’s storm drain discharges. Using this method’s standard intensity-duration curve table for the geographic area of the West Campus, rainfall intensities and corresponding time to concentration were determined. The time of concentration was determined for overland flow from the most upstream point in each drainage basin. Using this initial time of concentration, a cumulative total time was developed from the subsequent down stream sub-drainage basins. The size of each land use parcel was developed from those used in the LRDP. The runoff coefficients were established using standard methods and are shown below:

Land Use Designation	Runoff Coefficient (C)
Parking	0.90
Student Apartments	0.85
Academic	0.80
Family Housing	0.65
Childcare	0.60
Green Space	0.50

Using the parameters and method described above, the resulting 10-year storm water discharge rate will be approximately 150 cfs, which is less than the allowed 169 cfs.

The storm drain system will direct storm flows to the southwest by the use of ornamental drainage swales as detention basins and outlet controls. The ornamental drainage swales flow to the west discharging into a new drain line between Cranford Street and Iowa Avenue. Storm flow to the west of this proposed drain line will discharge into the existing drain line in Cranford Street. Both drain lines connect to the existing line in Martin Luther King Boulevard which flows to the west discharging at the Kansas Street Retention Basin.

Pipe and Ornamental Swale Sizing

The ornamental drainage swales were assumed to have a trapezoidal geometric shape with side wall slope ratios of 1 vertical to 2.5 horizontal and a maximum flow velocity of 5.5 feet per second (ft/s). To allow a maximum velocity of 5.5 ft/s the channel bottom and side walls were assumed to be constructed with coarse gravel or larger sized non-colloidal particles. The side wall slope, channel construction material, and maximum flow velocity were determined to reduce possible channel erosion. Manning's equation "n" was assumed to be a minimum of 0.025 for this type of channel. The maximum channel slope was 0.015 feet per foot which is the average existing slope from east to west across the West Campus before development. The trapezoid shaped channel dimensions are shown below:

Channel Dimension	Length (ft)
Bottom Width	6
Channel Depth	3
Top Width	21

This channel geometry with the parameters detailed above conveys approximately 45 cfs with a one foot water depth. There is an additional two foot channel depth freeboard. Storm discharges into the swales are less than 45 cfs during a 10 year storm event.

The connection between ornamental swales at street crossings will be made with conduit equal to or greater than 18-inches in diameter. The conduit inlet should be sized to control the flow discharge rates into the downstream swales and to prevent overflow of the upstream swale during a 10-year storm event. This flow control is necessary to increase the time of concentration, thus reducing the total West Campus storm discharge rate during a storm event.

The drainage swales will discharge into a collection pipe located between Cranford Street and Iowa Avenue. This drain pipe was sized to accommodate all upstream discharges from the ornamental drainage swales for connection to the existing line in Martin Luther King Boulevard. The pipe was sized to flow three quarters full during the 10-year storm event.

Figure 27 Drainage Plan

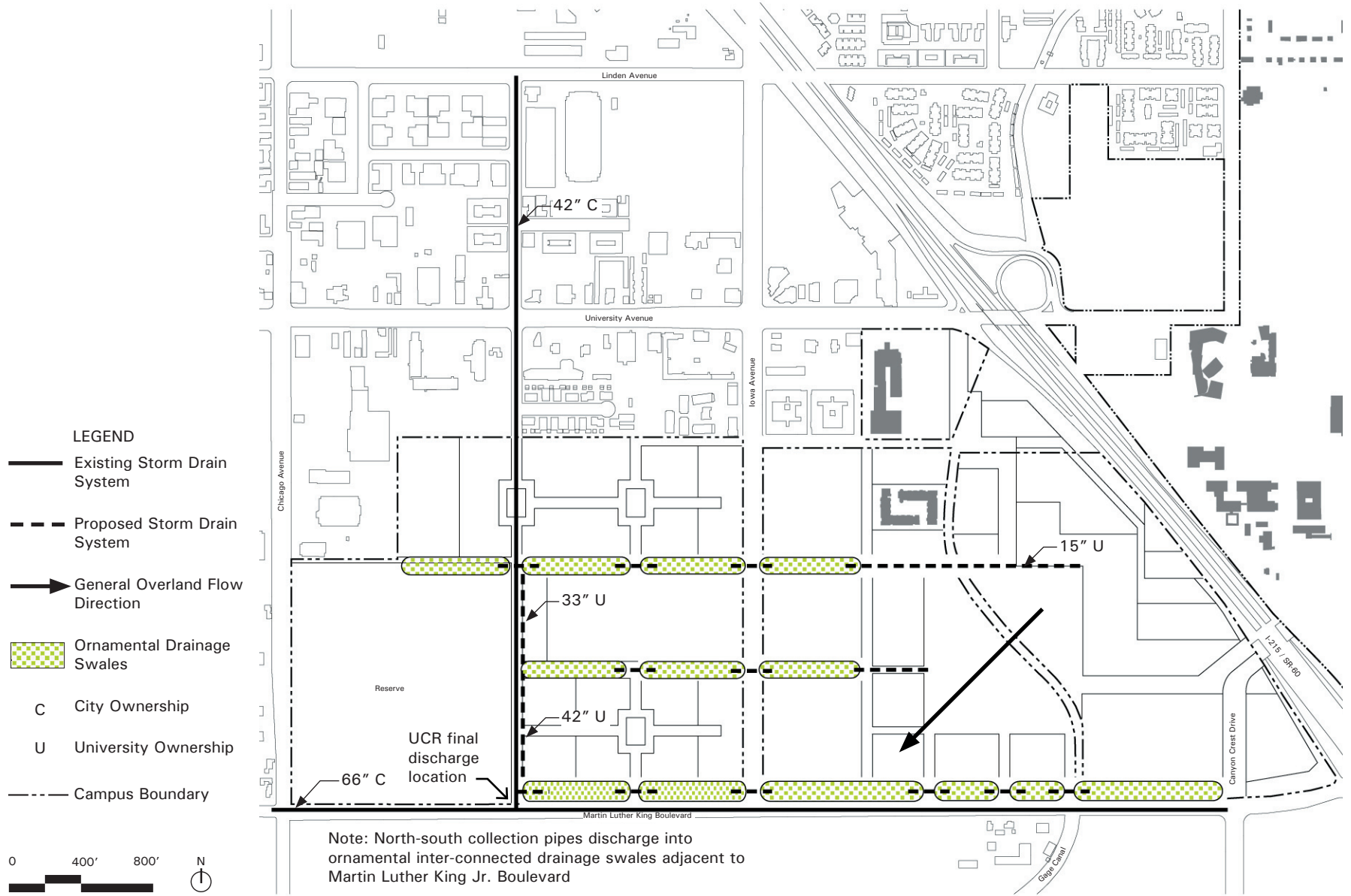

Water

Based on planned enrollment growth and expansion of programs, facilities and housing, West Campus population, for purposes of projecting water and sewer demand, is estimated to be 10,856 students, faculty, staff, and visitors. This population includes 714 students living in family housing and 2,787 students living in apartments. In addition, 1,428 non-student family members will live in the 714 family housing units.

Existing West Campus

The West Campus domestic water system is connected directly to the City of Riverside water system and is therefore independent from the East Campus water system. Existing City water lines serving the West Campus perimeter are as shown on Figure 28, and are located in University Avenue, Everton Place, Martin Luther King Boulevard, Chicago Avenue, Iowa Avenue, and Cranford Avenue. Agricultural lands are irrigated with water from the Gage Canal. Existing City water service is provided to the International Village housing complex through an 8-inch water line extending south in Iowa Avenue from University Avenue and turning east in Everton Place. UNEX, Highlander Hall and Human Resources Building receive potable water from service connections in University Avenue.

Existing domestic water use by the West Campus is less than 200,000 gallons per day. Information provided by the City of Riverside indicates that at the corner of Iowa Avenue and Everton Place, system pressure ranges from 77 to 86 pounds per square inch (psi). Residual pressure at this location at a flow of 1,561 gallons per minute was reported at 72 psi. These pressure readings indicate that the City's system has adequate pressure for future service to the West Campus.

Projected Water Demand

The 2003 Long Range Development Plan projects water demands for future construction using sustainable water use factors (comparable to those used in the planning for the new University of California Merced campus, the most recent new UC campus to be planned, and other UC campuses). These sustainable water use factors are 70 gallons per day (gpd) for students living on campus and 20

gpd for all students, faculty, staff, and visitors not living on campus.

The sustainable domestic water use historically comprises 40% of the total potable water demand for the campus, therefore landscape irrigation demand needs to be added to the calculated domestic consumption as approximately 60% of the total domestic demand. This does not include the water irrigation demand for the UCR agricultural lands on the West Campus that are irrigated from the Gage Canal.

The following table summarizes estimated water demand for the West Campus:

Classification	Users x Demand GPD	Daily Demand GPD
Students In Apartments	2,787 @ 70 =	195,090'
Students In Family Housing	714 @ 70 =	49,980
Non-Students In Family Housing	2 x 714 @ 70 =	99,960
Students, Faculty, Staff, and Visitors	(10,856 - 3,501) @ 20 =	147,100
Total Domestic Demand		492,130
Landscape Irrigation Demand @ 60% of Total	(492,130 / 40%) - 492,130 =	738,195
Total West Campus Demand		1,230,325

The total projected average domestic and landscape irrigation water demand is approximately 1.2 MGD. Demand may vary somewhat depending on the academic building program ultimately implemented on the West Campus.

Development of the West Campus for housing and academic uses will decrease the agricultural area and consequently agricultural irrigation water demand. This may result in an increased availability of water from the Gage Canal. Gage Canal water, however, cannot be used directly for domestic use without treatment, direct piping from the well supplying the canal, and probable storage for equalizing supply. Likewise, Gage Canal water cannot be used for landscape irrigation unless it is delivered in a separate piping system from the domestic supply. This plan does not address the water quality issues or conditions required for using Gage Canal water as a future source for either domestic use or landscape irrigation.

Figure 28 Water Plan

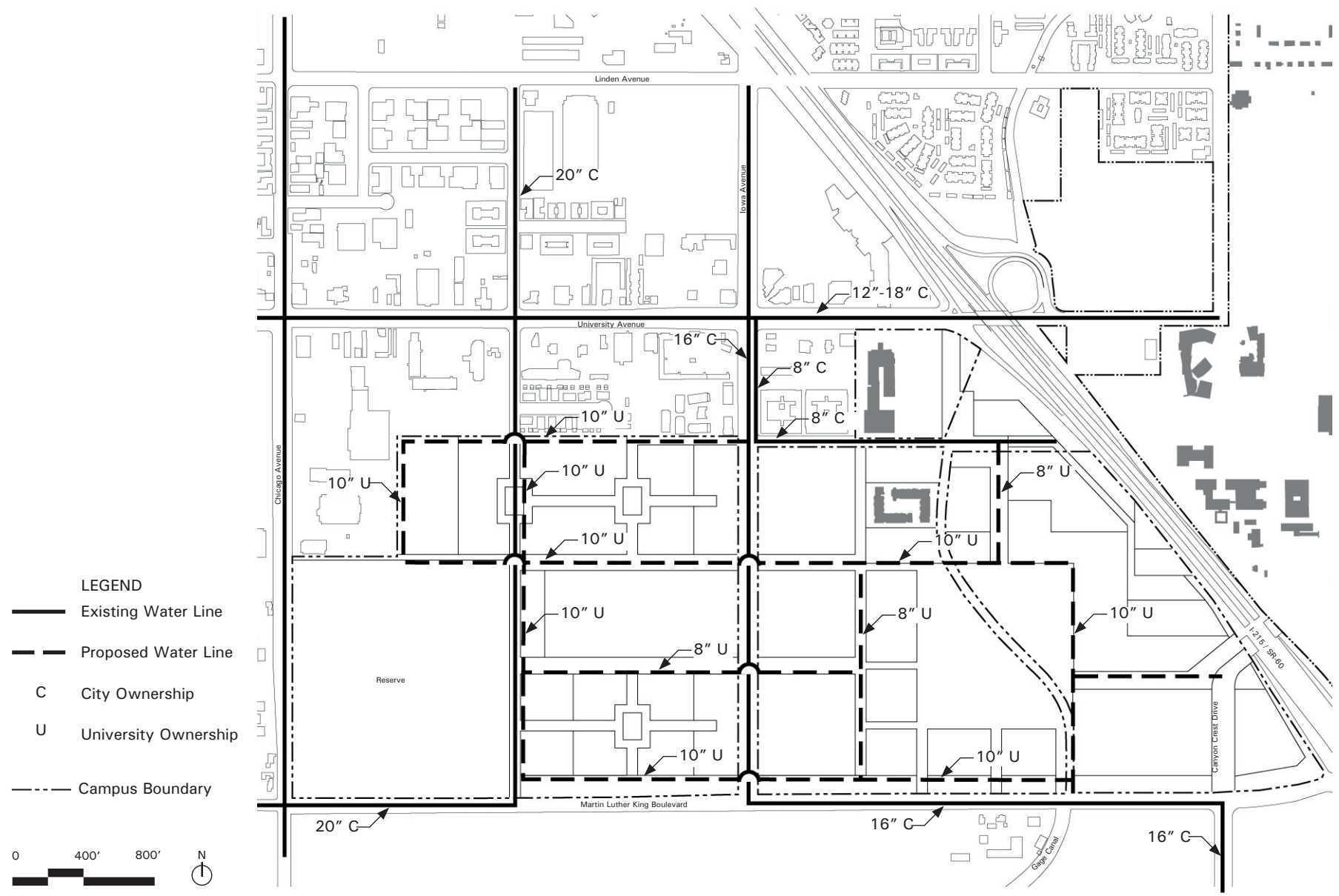

Proposed Water System

Water will be provided in looped systems around major developed areas, providing flow from two directions and redundancy of supply and pressure. Two primary metered connections are proposed to the City's existing 16-inch main line that bisects the West Campus north/south in Iowa Avenue and west/east along Martin Luther King Boulevard, as shown on Figure 28. The City metered connections will be near the corner of Martin Luther King Boulevard and Canyon Crest Drive and at the intersection of Iowa Avenue and Everton Place. Future facility water use will be metered individually; each service lateral from the main line distribution will be installed with its own meter.

Pipe Sizing

Pipe sizing is based on desired flow criteria for the ultimate system, with phasing generally proceeding from east to west, and with the initial connection to the City's service near the intersection of Martin Luther King Boulevard and Canyon Crest Drive. The main lines forming the backbone of the looped supply will be 10-inches in diameter. This size was selected to accommodate a 3,000 gpm fire flow, a maximum daily domestic flow of 1,700 gpm (not including landscape irrigation), as determined by multiplying the average day demand of approximately 850 gpm by a factor of 2.0, while maintaining a fire flow maximum velocity of 14 feet per second (fps). Secondary loop piping sections were reduced to 8-inch diameter as a minimum.

Gas

The projected gas demand of the West Campus is 16,000 Therms/day. The demand will be met by the phased expansion of the Southern California Gas infrastructure on Martin Luther King Boulevard and University Avenue.

Electrical

The West Campus has no electrical infrastructure beyond the development that has already taken place along University Avenue, at International Village Housing, and at Parking Lot 30. Additional distribution circuits will need to be routed in the West Campus as it develops. The proposed routing of these circuits is shown in Figure 30. The proposed infrastructure is shown as a dual-radial distribution with both feeders enclosed in the same duct bank, identical to the existing distribution scheme of the East Campus.

There are above-ground, high voltage transmission lines traversing a portion of the West Campus. These lines will have to be relocated. The proposed relocation route is shown in Figure 31.

Chilled Water

Future West Campus chilled water demand is estimated at 4,000 tons. The low density demand on the West Campus and the distance from the East Campus, as well as the difficulty and expense that would be required to run lines under the freeway, preclude extension of the East Campus system to the west.

As a consequence, West Campus cooling load requirements will be addressed on a project-by-project basis. Where local densities and phasing are favorable, chilled water systems can be developed incrementally to serve groups of buildings, which will allow buildings to employ emerging technologies for efficiencies in cooling, and avoid the need for a central chilled water system with high pumping head. Electrically generated cooling will be used and has been incorporated in the electrical infrastructure.

Steam

Based on current consumption on the East Campus, the projected West Campus steam demand is estimated at 96,000 lb/hr and the existing central steam plant has potential capacity to meet this demand. However, for the same reasons that the chilled water system will not be extended from the East Campus – long distances and the need to run the piping under the freeway – it is not envisioned that the hot water/steam system for the West Campus be connected to the east side either.

The West Campus academic buildings are projected to be of low energy intensity and no wet labs are envisioned at this time. As a consequence there is no need for process steam to be provided on the West Campus. High efficiency gas boilers supplying individual buildings or clusters of buildings in a sector can best meet West Campus space-heating needs. In the event that a wet lab requiring steam is located on the west side, individual gas fired steam generators can be used.

Figure 29 Gas Plan

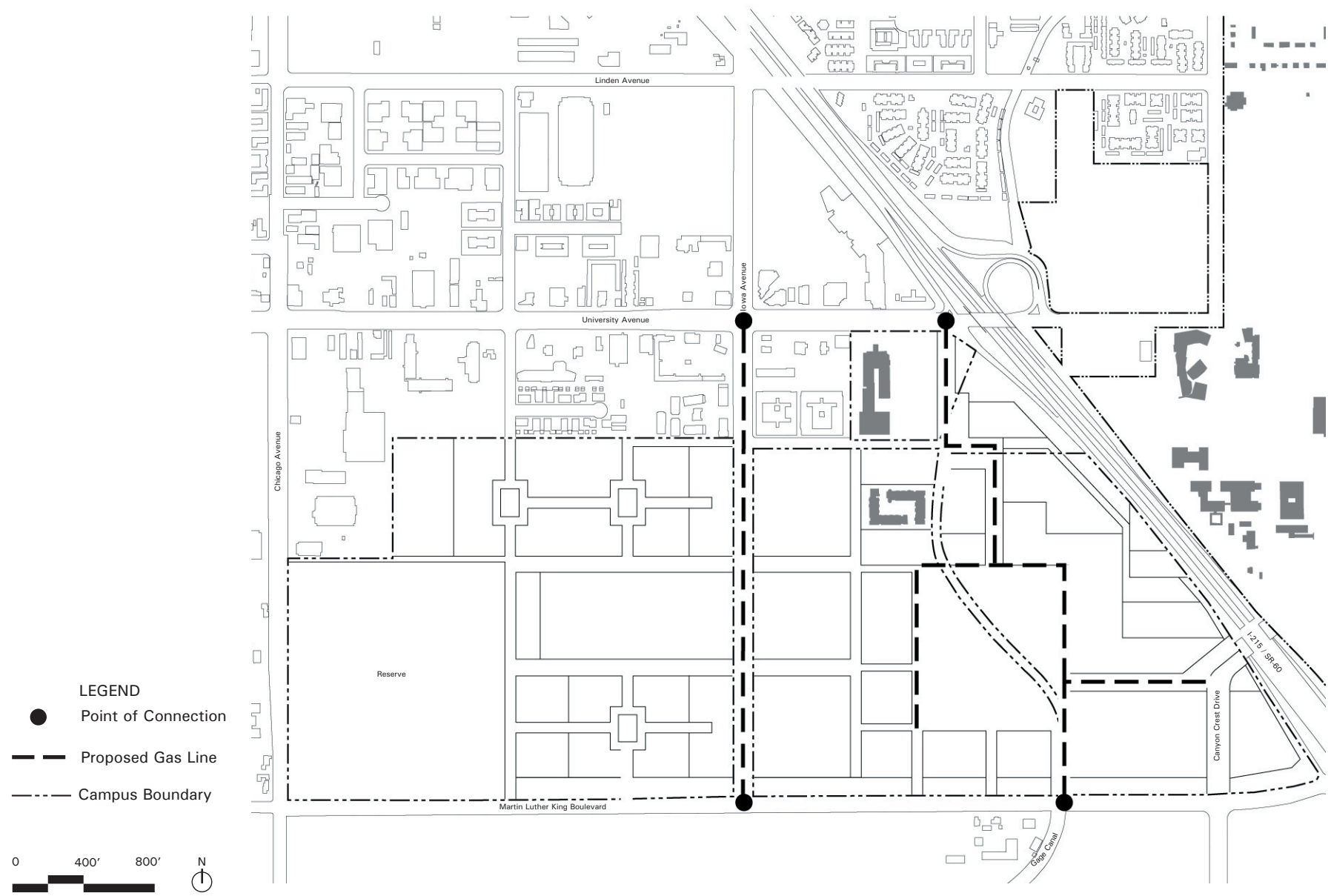

Figure 30 Electrical Plan

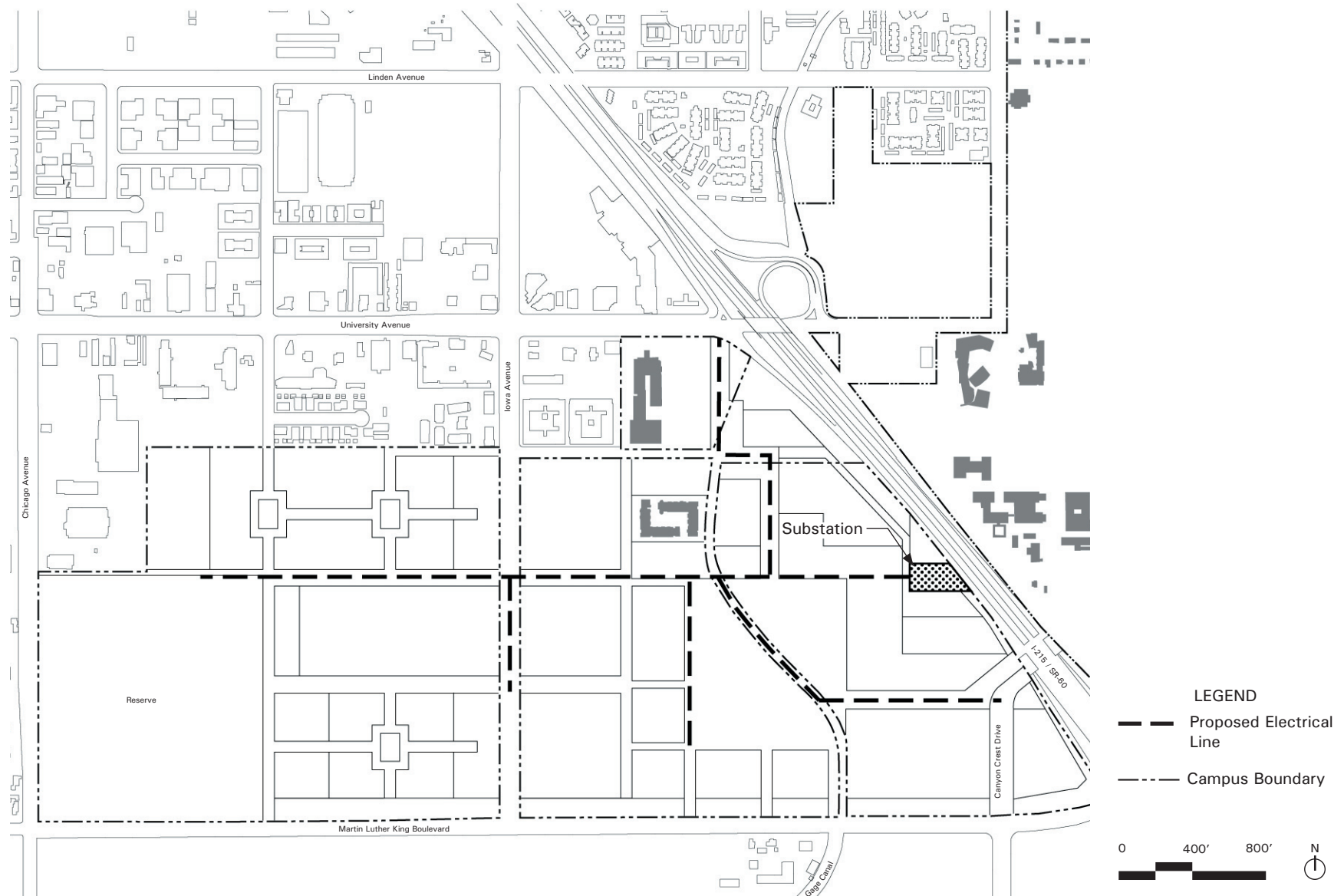
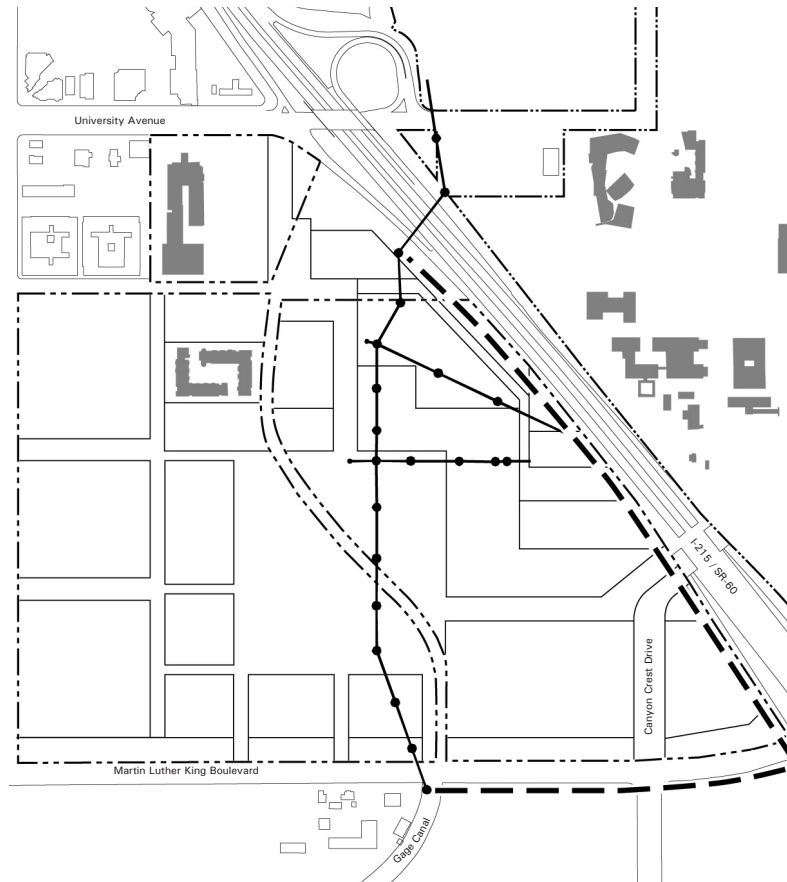

Figure 31 Transmission Line Plan



LEGEND

- Existing Transmission Line
- Campus Boundary
- Proposed Transmission Line





DEVELOPMENT STRATEGY

DEVELOPMENT STRATEGY

The timing, phasing and final composition of the West Campus will be determined by many factors, most of which cannot be accurately predicted at this time. Nonetheless, articulation of a development strategy for the West Campus is important to lend a methodology and set of principles to guide development decisions as they arise over time.

Aspects of the development strategy include:

Phasing Strategy

This is a description of the order of development of land uses and parcels and their supporting infrastructure (roads, utilities and open space).

Cost Estimates

The predicted costs of those infrastructure elements of the development plan that are likely to be borne by UCR, as opposed to individual building projects - academic, housing or others - are included in this discussion.

Implementation Approach

Beyond an understanding of probable costs and the phasing of development, other considerations such as procedures for design review are articulated.

The sections that follow address these three components.

Phasing Strategy

Development of an area as large as the West Campus in a manner that makes the earliest phases feel like an integral part of UCR, requires a rational approach to the phasing of this growth.

The principles articulated below establish general rules for phasing of all uses and elements of the West Campus:

- Development must be phased to create a sense of completion and a sense of place from the first projects.
- Phasing must be oriented to achieving immediate connections with the East Campus and in particular the academic core via University Avenue and the Canyon Crest undercrossing.
- Construction of new projects must minimize disturbance to occupants of earlier facilities caused by construction.
- Phasing of buildings must facilitate a rational and cost-effective extension of infrastructure such as utility lines and connections.
- Phasing must also minimize costs of infrastructure needed to serve any phase and should also support the logical assignment of costs of affected buildings or development projects.
- The phasing of housing areas must result in the ongoing creation of critical mass to support a sense of community or neighborhood, and the support services that may be required.
- Phasing throughout the West Campus must ensure that safety and security of students, faculty and staff can be achieved and maintained during all stages of development.
- New buildings should generally be built as near as possible to existing buildings, to maintain a compact, pedestrian-oriented environment, and to avoid wasteful and disruptive leapfrog development patterns.

Long-term development of the West Campus has been divided into three stages to illustrate the general timing of land uses, facilities and infrastructure construction and accompanying major open space connections. These

stages represent a best estimate of probable timing and quantity of development. The actual timing and phasing of development will vary.

Initial Development Stage

The earliest development stage is expected to include family housing, childcare facilities, a limited number of academic buildings, and infrastructure (roads, utilities and open space) to support these first projects and to connect them to the East Campus.

Concurrent with construction of the first academic and housing facilities on the West Campus, it will be critical to establish the connections to the academic core of the East Campus. As a consequence, the early academic buildings are located immediately adjacent to freeway undercrossings to the East Campus: on Lot 30 directly opposite the Canyon Crest under-crossing, and within or adjacent to UNEX and Highlander Hall sites at University Avenue. This placement of buildings will begin to draw overall campus population into the West Campus and will allow Lot 30 to remain in use.

Housing development on the West Campus will begin with family housing, starting west of Iowa Avenue, below Everton Place. Amenities such as neighborhood parks and a childcare center will be implemented concurrently to provide a complete residential neighborhood environment. Recreation fields will also be a component of initial development stages.

An initial parking structure may be included in this stage. A logical first site would be immediately adjacent to the freeway, which minimizes impacts to agricultural lands and is conveniently situated to absorb parking for commuters destined for the East Campus.

Infrastructure elements to serve these initial land uses will include extensions of basic utilities and improvements to Iowa and Cranford Avenues to serve the housing neighborhood. Construction of portions of Northwest and Southwest Malls will provide pedestrian and bicycle connections to the east, and initial components of the swale drainage system.

Figure 32 Initial Development Stage

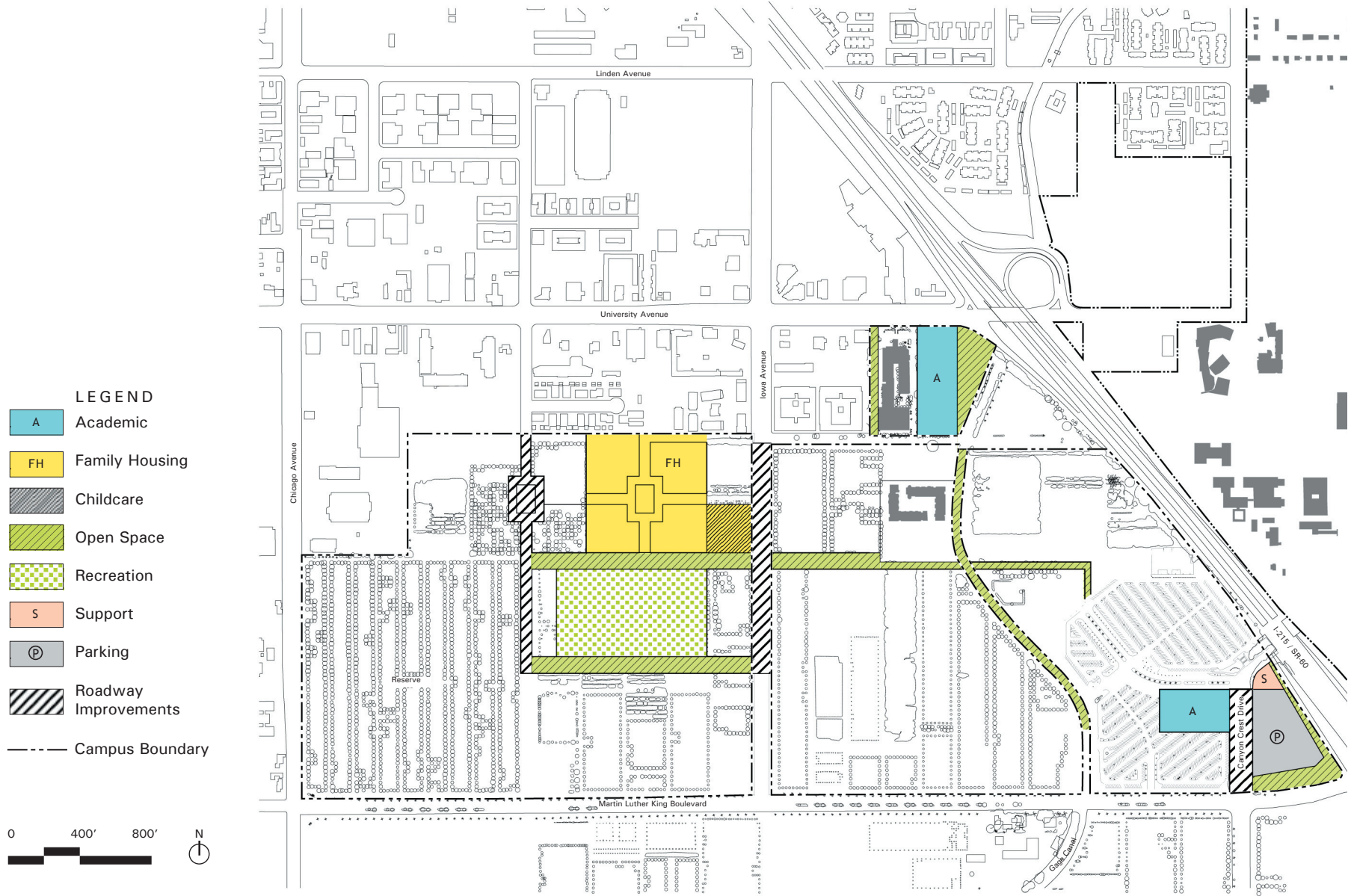

- LEGEND**
- Academic
 - Family Housing
 - Childcare
 - Open Space
 - Recreation
 - Support
 - P Parking
 - Roadway Improvements
 - Campus Boundary

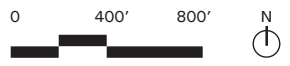

It is also suggested that in this stage the entirety of the Gage Canal be covered to put in place an additional link in the bicycle and pedestrian systems.

Areas that are not developed during this stage may remain in agricultural research. As noted, Lot 30 also remains in use.

Intermediate Stage

The intermediate stage of development will be the period in which the West Campus achieves a true critical mass and identity and emerge as a destination within the larger UCR campus. At this time particular attention will need to be paid to incorporating the major identity features and “Image” elements. This stage is defined relatively broadly, since development is likely to be proceeding more rapidly by this time.

Development of family housing will continue in completion of most of these units. This will result in the creation of several family housing neighborhoods, each with childcare, parks, tot lots and other amenities. It will continue to be important to link these neighborhoods east to the West Campus academic core and to the East Campus via malls and other connections.

During this time it is expected that apartment housing will also begin to be developed in the West Campus, providing housing opportunities for graduate and upperclass UCR students.

The academic areas will proceed to develop, trending in a south and west direction, defining the primary open space of the West Campus, The Grove. Academic buildings should be planned to line the major pedestrian corridors - University and Canyon Crest Malls.

The Grove should be implemented in this stage, although cultivation of the trees to be included should begin earlier in a nursery, preferably on site. As discussed in earlier sections, The Grove will consist of many elements - academic and student service buildings, public art, events venues, as well as literal and metaphoric citrus groves. Not all of these elements will be implemented initially, but can be added over time as funding allows.

Infrastructure elements will be provided to keep pace with the development of facilities noted above. Since development will have extended to a large area, much of the backbone infrastructure system will be completed. Roads will also largely be completed, except in a few areas not yet requiring general, service or emergency access.

During this phase, it will be important to extend pedestrian and bicycle connections throughout the West Campus, to ensure that all developed areas can be easily accessed and to encourage walking, and the use of shuttles and bicycles for movement.

Figure 33 Intermediate Stage

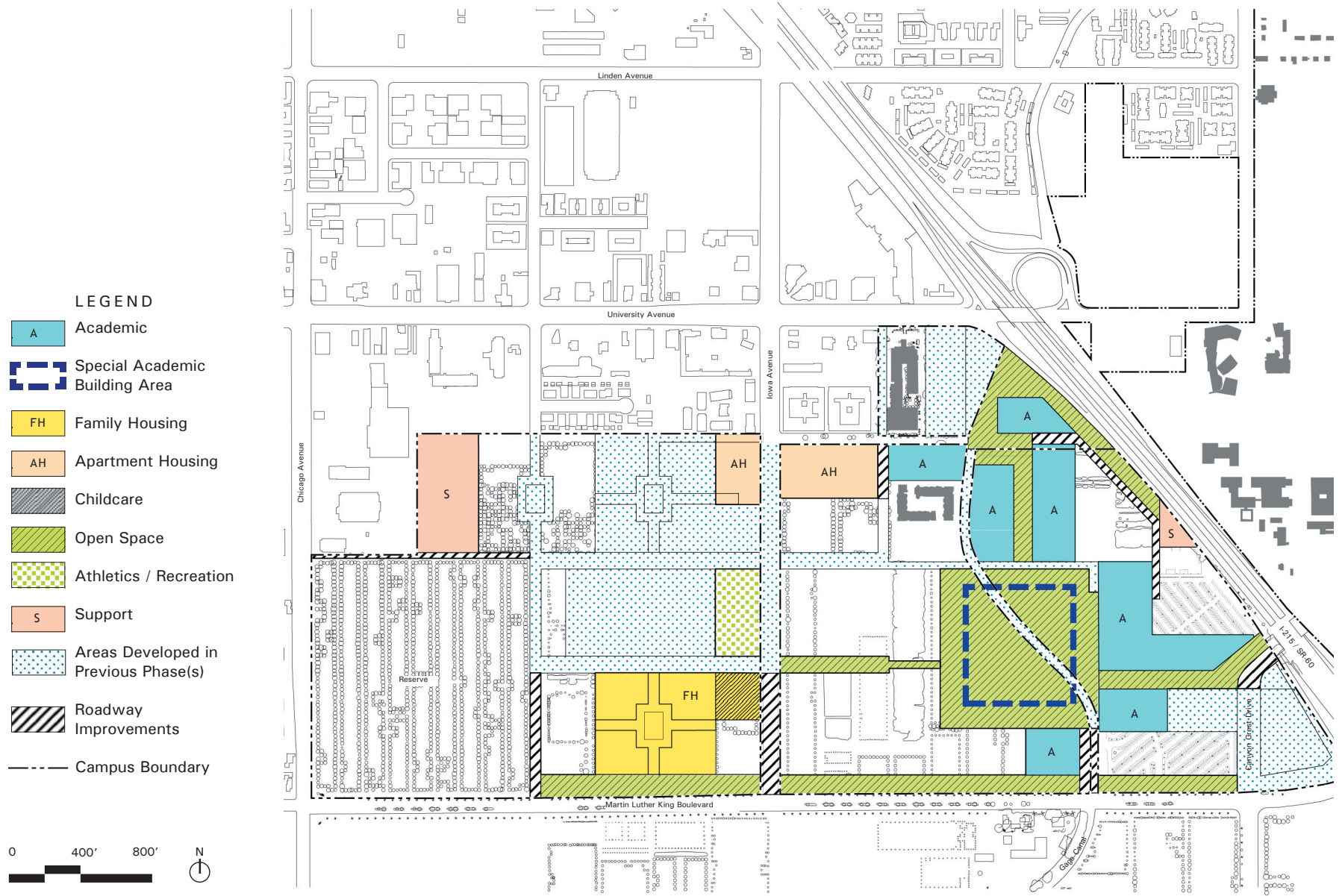

Ultimate Development Stage

The final development stage of the West Campus will complete implementation of all facilities and infrastructure.

In housing areas, final elements of apartment housing are completed. By this time infrastructure has been completed, so housing units and some support uses are the primary activity. Roads, parks, infrastructure and circulation networks have already been completed.

In this stage academic uses infill remaining sites. Parking is also added, which at this point in the development of the campus, is likely to be in the form of parking structures, located along Martin Luther King Boulevard.

Figure 34 Ultimate Development Stage

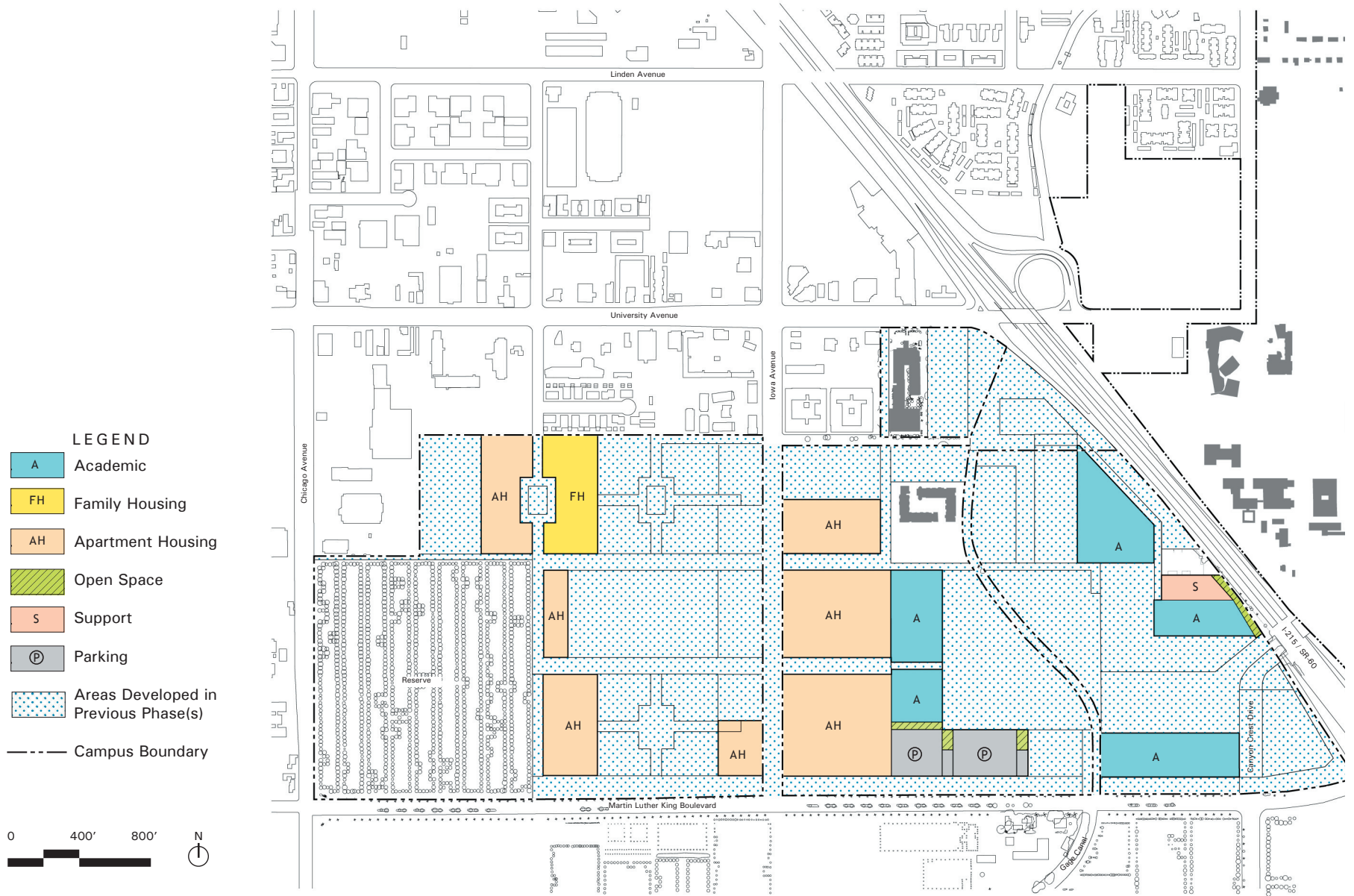

Infrastructure Costs

During each stage of development of West Campus improvements, a backbone infrastructure system must be established to allow building development to proceed. Infrastructure projects include street and service road improvements, malls, pedestrian paths, open space, drainage and sanitary sewer systems, and utilities necessary to serve the campus. The Development Stage diagrams on the previous pages illustrate all projects in each phase of campus development. The following Infrastructure Project Phasing diagrams indicate the infrastructure projects that must be provided for each phase. Due to the size of the West Campus, it is anticipated that many of the major infrastructure elements - such as roads and malls - will be built as more than one project, in more than one phase.

Total estimated costs for each Development Stage are summarized in the table at right, and detailed in the Cost Summary tables on the following pages.

Cost Assumptions

Costs include all above- and below-ground infrastructure improvements for the West Campus.

Estimated costs are based on the level of detail of this Plan and include a 35% contingency to accommodate unforeseen circumstances during the detailed design phases and construction process.

No geotechnical investigation was conducted to provide recommendations for construction methods. All assumptions made for proposed pavement sections, grading, etc. are for pricing purposes only.

Estimated costs do not include right-of-way acquisition, resolution of unknown utility crossings, over-excavation, nor environmental mitigation measures.

Agency/utility fees are not included.

Cost Summary

	Construction Cost	35% Contingency	Total Phase Cost
Phase One	\$13,939,460	\$4,878,810	\$18,818,000
Phase Two	\$16,456,600	\$5,760,860	\$22,220,500
Phase Three	\$1,105,400	\$386,890	\$1,492,300
Total Project Cost			\$42,531,100

High Voltage Transmission Line Relocation

\$270,000

This estimate does not include any work to prepare new development sites (e.g., demolition of existing buildings, removal of existing parking lots, utility connections, etc.) unless otherwise noted.

On-campus signalization and off-campus signalization improvements/upgrades are not included in the cost estimate.

Estimated costs include construction/installation costs only, and do not include soft costs such as legal, engineering, design, project management, nor maintenance costs.

Services performed to produce this Cost Estimate are consistent with the level of care and skill ordinarily exercised in the same locality under similar conditions. No other representation or opinion, expressed or implied, and no warranty or guarantee is included or intended in this cost estimate.

Figure 35 Infrastructure Project
 Phasing: Initial Development Stage

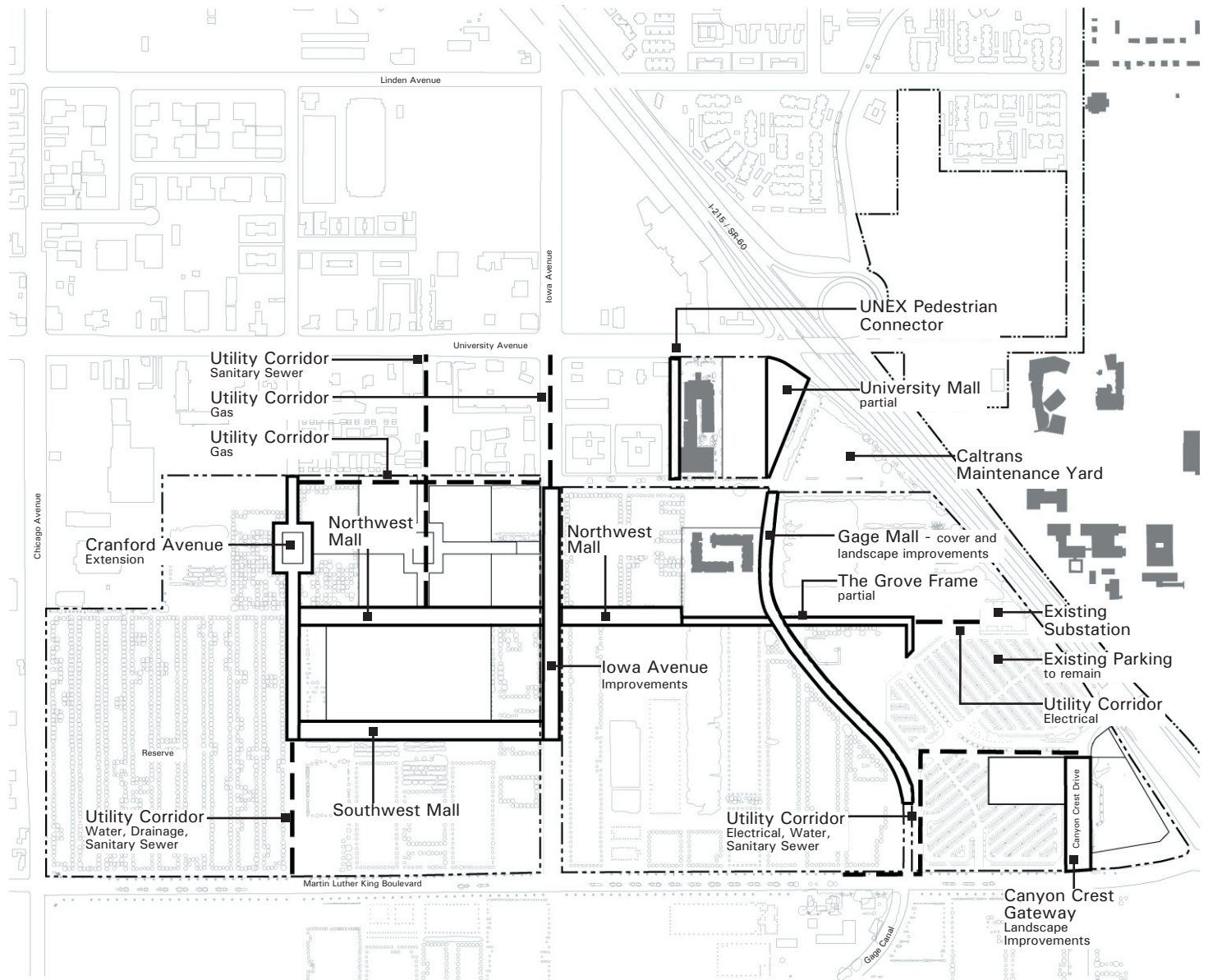

Figure 36 Infrastructure Project
Phasing: Intermediate
Stage

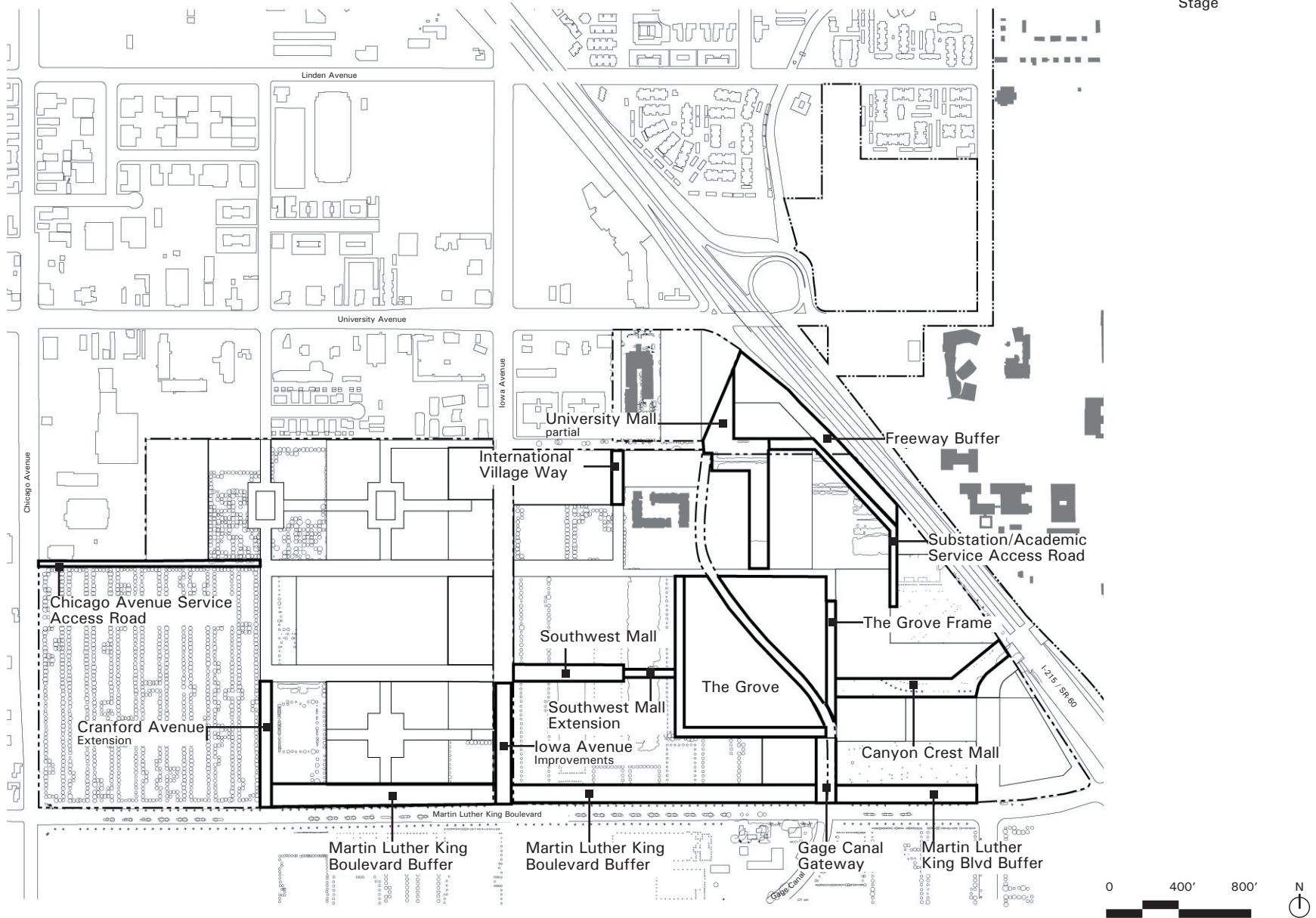
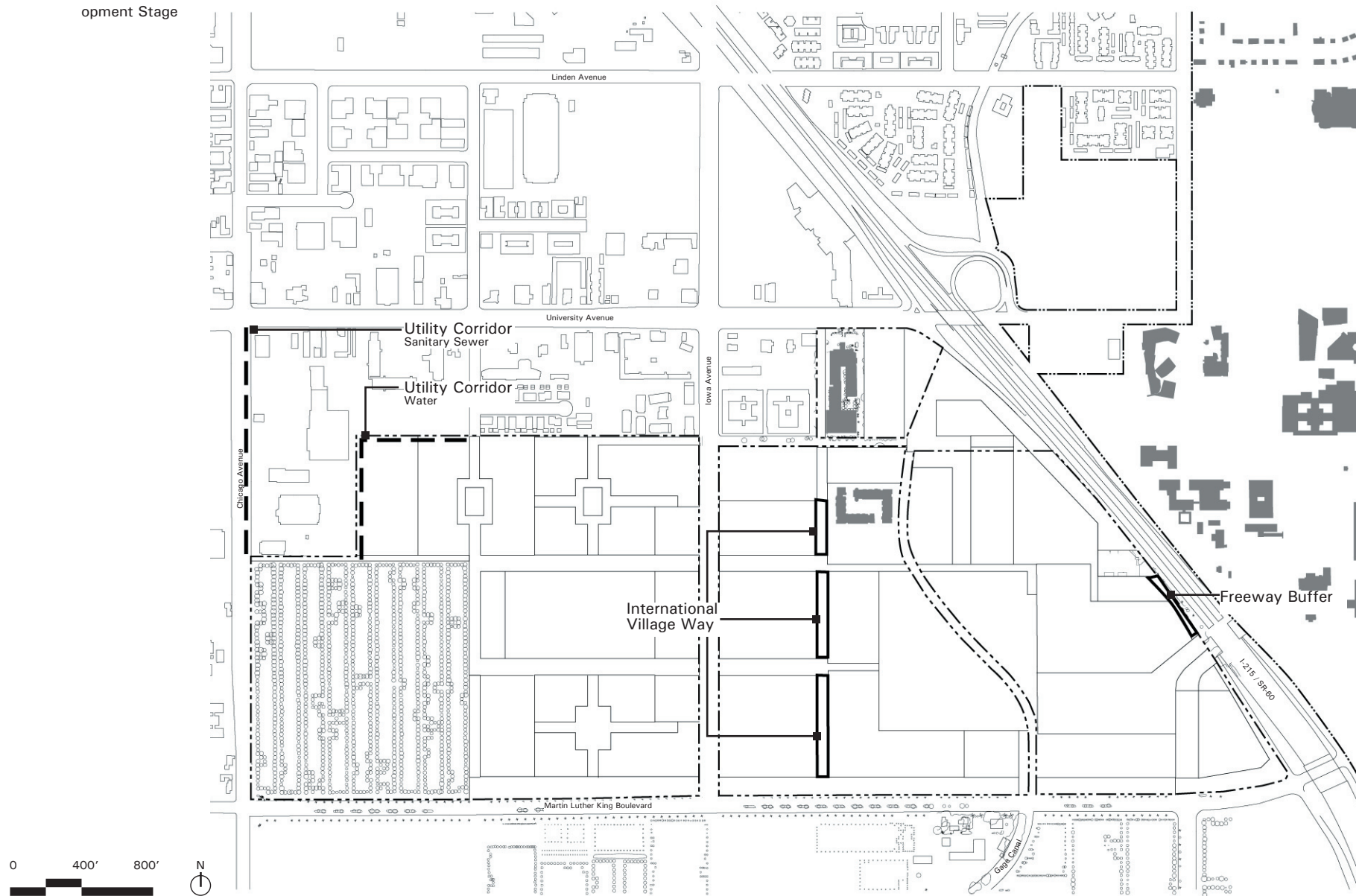

Figure 37 Infrastructure
Project Phasing:
Ultimate Develop-
ment Stage



STREETS AND SERVICE ROUTES

	Phase One				Phase Two				Phase Three			
	Quantity	Unit	Cost / Unit	Total Cost	Quantity	Unit	Cost / Unit	Total Cost	Quantity	Unit	Cost / Unit	Total Cost
CRANFORD AVENUE EXTENSION (NEW)	1,400	L.F.			700	L.F.			0	L.F.		
Subgrade preparation	1,400	LF	\$1	\$1,400	700	LF	\$1	\$700				
Paving	50,400	SF	\$4	\$201,600	25,200	SF	\$4	\$100,800				
Curb and gutter	2,800	LF	\$15	\$42,000	1,400	LF	\$15	\$21,000				
Signage and striping	1,400	LF	\$5	\$7,000	700	LF	\$5	\$3,500				
Sidewalk - concrete	16,800	SF	\$5	\$84,000	8,400	SF	\$5	\$42,000				
Utilities (gas, water, electrical)	1,400	LF	\$125	\$175,000	0	LF		\$0				
Drainage	700	LF	\$450	\$315,000	0	LF		\$0				
Sanitary sewer	0	LF		\$0	0	LF		\$0				
Planting and irrigation												
Street trees	2,800	LF	\$14	\$39,200	1,400	LF	\$28	\$39,200				
Groundplane and irrigation	16,800	SF	\$5	\$84,000	8,400	SF	\$5	\$42,000				
Street lighting	2,800	LF	\$35	\$98,000	1,400	LF	\$35	\$49,000				
Cranford Avenue Subtotal				\$1,047,200				\$298,200				
IOWA AVENUE (UPGRADE)	1,330	L.F.			680	L.F.			0	L.F.		
Subgrade preparation	1,330	LF	\$1	\$1,300	680	LF	\$1	\$700				
Paving	39,900	SF	\$4	\$159,600	20,400	SF	\$4	\$81,600				
Curb and gutter	2,660	LF	\$15	\$39,900	1,360	LF	\$15	\$20,400				
Signage and striping	1,330	LF	\$5	\$6,700	680	LF	\$5	\$3,400				
Sidewalk - concrete	21,280	SF	\$5	\$106,400	10,880	SF	\$5	\$54,400				
Utilities (gas, water, electrical)	2,000	LF	\$140	\$280,000	680	LF	\$60	\$90,800				
Drainage	0	LF		\$0	0	LF		\$0				
Sanitary sewer	330	LF	\$100	\$33,000	340	LF	\$155	\$52,700				
Planting and irrigation												
Street trees	5,320	LF	\$14	\$74,500	2,720	LF	\$14	\$38,100				
Groundplane and irrigation	47,880	SF	\$5	\$239,400	24,480	SF	\$5	\$122,400				
Street lighting	2,660	LF	\$28	\$74,500	1,360	LF	\$28	\$38,100				
Iowa Avenue Subtotal				\$1,015,300				\$502,600				
UNEX PEDESTRIAN CONNECTOR	610	L.F.			0	L.F.			0	L.F.		
Subgrade preparation	610	LF	\$1	\$600								
Pedestrian paving - concrete	12,200	SF	\$18	\$219,600								
Curb and gutter	1,220	LF	\$15	\$18,300								
Utilities (gas, water, electrical)	0	LF		\$0								
Drainage	0	LF		\$0								
Sanitary sewer	0	LF		\$0								
Planting and irrigation												
Trees	2,440	LF	\$14	\$34,200								
Groundplane and irrigation	21,960	SF	\$5	\$109,800								
Street lighting	1,220	LF	\$35	\$42,700								
Street furniture	610	LF	\$10	\$6,100								
Wayfinding signage	610	LF	\$0.75	\$460								
UNEX Pedestrian Connector Subtotal				\$431,760								

STREETS AND SERVICE ROUTES

	Phase One				Phase Two				Phase Three			
	Quantity	Unit	Cost / Unit	Total Cost	Quantity	Unit	Cost / Unit	Total Cost	Quantity	Unit	Cost / Unit	Total Cost
INTERNATIONAL VILLAGE STREET	0 L.F.				310 L.F.				790 L.F.			
Subgrade preparation					310 LF		\$1	\$300	1,360 LF		\$1	\$1,400
Paving					11,160 SF		\$4	\$44,600	48,960 SF		\$4	\$195,800
Curb and gutter					620 LF		\$15	\$9,300	2,720 LF		\$15	\$40,800
Signage and striping					310 LF		\$5	\$1,600	1,360 LF		\$5	\$6,800
Sidewalk - concrete					3,720 SF		\$5	\$18,600	16,320 SF		\$5	\$81,600
Utilities (gas, water, electrical)					0 LF			\$0	1,060 LF		\$105	\$111,300
Drainage					0 LF			\$0	0 LF			\$0
Sanitary sewer					0 LF			\$0	285 LF		\$155	\$44,200
Planting and irrigation												
Street trees					620 LF		\$14	\$8,700	2,720 LF		\$14	\$38,100
Groundplane and irrigation					3,720 SF		\$5	\$18,600	16,320 LF		\$5	\$81,600
Street lighting					620 LF		\$35	\$21,700	2,720 LF		\$35	\$95,200
International Village St. Subtotal								\$123,400				\$696,800
CHICAGO AVE. SERVICE ACCESS ROAD	0 L.F.				1,210 L.F.				0 L.F.			
Subgrade preparation					1,210 LF		\$1	\$1,200				
Paving					24,200 SF		\$4	\$96,800				
Curb and gutter					2,420 LF		\$15	\$36,300				
Signage and striping					1,210 LF		\$5	\$6,100				
Sidewalk - concrete					0 SF		\$5	\$0				
Utilities (gas, water, electrical)					605 LF		\$405	\$245,000				
Drainage					605 LF		\$150	\$90,800				
Sanitary sewer					1,210 LF		\$100	\$121,000				
Planting and irrigation (street trees/groundcover)					0 LF			\$0				
Street lighting					1,210 LF		\$14	\$16,900				
Chicago Ave. Service Access Rd. Subtotal								\$614,100				
SUBSTATION/ACADEMIC SERVICE ACCESS RD.	0 L.F.				1,320 L.F.				0 L.F.			
Subgrade preparation					1,320 LF		\$1	\$1,300				
Paving					26,400 SF		\$4	\$105,600				
Curb and gutter					2,640 LF		\$15	\$39,600				
Signage and striping					1,320 LF		\$5	\$6,600				
Sidewalk - concrete					0 SF		\$5	\$0				
Utilities (gas, water, electrical)					0 LF			\$0				
Drainage					0 LF			\$0				
Sanitary sewer					0 LF			\$0				
Planting and irrigation (street trees/groundcover)					0 LF			\$0				
Street lighting					1,320 LF		\$14	\$18,500				
Chicago Ave. Service Access Rd. Subtotal								\$171,600				
MLK. BLVD STREETSCAPE	0 L.F.				3,730 L.F.				0 L.F.			
Sidewalk - concrete					22,380 SF		\$5	\$111,900				
Planting and irrigation												
Street trees					3,730 LF		\$14	\$52,200				
Groundplane and irrigation					22,380 SF		\$5	\$111,900				
Chicago Ave. Service Access Rd. Subtotal								\$276,000				
Streets and Service Routes Total								\$2,494,260	Streets and Service Routes Total			\$1,985,900
									Streets and Service Routes Total			\$696,800

MALLS

	Phase One				Phase Two				Phase Three			
	Quantity	Unit	Cost / Unit	Total Cost	Quantity	Unit	Cost / Unit	Total Cost	Quantity	Unit	Cost / Unit	Total Cost
NORTHWEST MALL	1,830 L.F.				0 L.F.				0 L.F.			
Subgrade preparation	1,830	LF	\$1	\$1,800								
Paving	73,200	SF	\$4	\$292,800								
Curb and gutter	7,320	LF	\$15	\$109,800								
Signage and striping	1,830	LF	\$5	\$9,200								
Sidewalk - concrete	21,960	SF	\$5	\$109,800								
Utilities (gas, water, electrical)	1,830	LF	\$425	\$777,800								
Ornamental drainage/detention swale	73,200	SF	\$17	\$1,244,400								
Drainage	1,830	LF	\$150	\$274,500								
Sanitary sewer	1,226	LF	\$100	\$122,600								
Planting and irrigation												
Street trees	3,660	LF	\$14	\$51,200								
Groundplane and irrigation (included in swale)	0	SF		\$0								
Street lighting	5,490	LF	\$35	\$192,200								
Street furniture	1,830	LF	\$10	\$18,300								
Wayfinding signage	1,830	LF	\$4	\$7,300								
Northwest Mall Subtotal				\$3,211,700								
SOUTHWEST MALL	1,230 L.F.				610 L.F.				0 L.F.			
Subgrade preparation	1,230	LF	\$1	\$1,200	610	LF	\$1	\$600				
Paving	49,200	SF	\$4	\$196,800	24,400	SF	\$4	\$97,600				
Curb and gutter	4,920	LF	\$15	\$73,800	2,440	LF	\$15	\$36,600				
Signage and striping	1,230	LF	\$5	\$6,200	610	LF	\$5	\$3,100				
Sidewalk - concrete	14,760	SF	\$5	\$73,800	7,320	LF	\$5	\$36,600				
Utilities (gas, water, electrical)	1,230	LF	\$105	\$129,200	610	LF	\$105	\$64,100				
Ornamental drainage/detention swale	49,200	LF	\$17	\$836,400	24,400	LF	\$17	\$414,800				
Drainage	1,230	LF	\$150	\$184,500	610	LF	\$150	\$91,500				
Sanitary sewer	0	LF		\$0	0	LF		\$0				
Planting and irrigation												
Street trees			\$14				\$14					
Groundplane and irrigation (included in swale)												
Street lighting	3,690	LF	\$35	\$129,200	1,830	LF	\$35	\$64,100				
Street furniture	1,230	LF	\$10	\$12,300	610	LF	\$10	\$6,100				
Wayfinding signage	1,230	LS	\$4	\$4,900	610	LS		\$0				
Southwest Mall Subtotal				\$1,648,300				\$815,100				
SOUTHWEST MALL EXTENSION	0 L.F.				290 L.F.				0 L.F.			
Subgrade preparation					290	LF	\$1	\$300				
Pedestrian paving - concrete					5,800	SF	\$18	\$104,400				
Curb and gutter					580	LF	\$15	\$8,700				
Utilities (gas, water, electrical)					0	LF		\$0				
Drainage					290	LF	\$200	\$58,000				
Sanitary sewer					0	LF		\$0				
Planting and irrigation												
Trees					580	LF	\$14	\$8,100				
Groundplane and irrigation					5,800	SF	\$5	\$29,000				
Street lighting					580	LF	\$35	\$20,300				
Street furniture					290	LF	\$10	\$2,900				
Wayfinding signage					290	LS	\$0.75	\$200				
Southwest Mall Extension Subtotal								\$231,900				

MALLS

	Phase One				Phase Two				Phase Three			
	Quantity	Unit	Cost / Unit	Total Cost	Quantity	Unit	Cost / Unit	Total Cost	Quantity	Unit	Cost / Unit	Total Cost
CANYON CREST MALL	0 L.F.				1,010 L.F.				0 L.F.			
Subgrade preparation					1,010 LF		\$1	\$1,000				
Gage Canal cover (not in contract - by others)					1,010 LF			\$0				
Pedestrian paving - concrete					36,360 SF		\$5	\$181,800				
Curb and gutter					3,200 LF		\$15	\$48,000				
Utilities (gas, water, electrical)					0 LF			\$0				
Drainage					0 LF			\$0				
Sanitary sewer					0 LF			\$0				
Planting and irrigation												
Trees					2,020 LF		\$14	\$28,300				
Groundplane and irrigation					64,640 SF		\$5	\$323,200				
Street lighting					2,020 LF		\$35	\$70,700				
Street furniture					1,010 LF		\$10	\$10,100				
Wayfinding signage					1,010 LF		\$0.75	\$800				
Canyon Crest Mall Subtotal								\$663,900				
UNIVERSITY MALL	70,320 S.F.				144,620 S.F.				0 S.F.			
Project costs based on Canyon Crest Mall cost	70,320 SF		\$10	\$703,200	144,620 SF		\$10	\$1,446,200				
Gage Canal cover	0			\$0	380 LF		\$465	\$176,700				
Utilities (gas, water, electrical)	380 LF			\$0	1,130 LF		\$405	\$457,700				
Drainage	0 LF			\$0	0 LF			\$0				
Sanitary sewer	380 LF		\$155	\$58,900	1,130 LF		\$100	\$113,000				
University Mall Subtotal				\$762,100				\$2,193,600				
GAGE MALL	1,850 L.F.				0 L.F.				0 L.F.			
Subgrade preparation	1,850 LF		\$1	\$1,900								
Gage Canal cover	1,850 LF		\$465	\$860,300								
Pedestrian paving - concrete	37,000 SF		\$18	\$666,000								
Curb and gutter	3,700 LF		\$15	\$55,500								
Utilities (gas, water, electrical)	800 LF		\$300	\$240,000								
Drainage	0 LF			\$0								
Sanitary sewer	0 LF			\$0								
Planting and irrigation												
Trees	3,700 LF		\$14	\$51,800								
Groundplane and irrigation	37,000 SF		\$5	\$185,000								
Street lighting	3,700 LF		\$35	\$129,500								
Street furniture	1,850 LF		\$10	\$18,500								
Wayfinding signage	1,850 LS		\$0.75	\$1,400								
Gage Mall Subtotal				\$2,209,900								
				Malls Total				\$7,832,000				
								Malls Total				\$3,904,500
												Malls Total
												\$0

GATEWAYS

	Phase One				Phase Two				Phase Three			
	Quantity	Unit	Cost / Unit	Total Cost	Quantity	Unit	Cost / Unit	Total Cost	Quantity	Unit	Cost / Unit	Total Cost
CANYON CREST GATEWAY	580 L.F.				0 L.F.				0 L.F.			
Subgrade preparation	580	LF	\$1	\$600								
Paving (not in contract - by others)	32,480	SF		\$0								
Curb and gutter (not in contract - in others)	2,320	LF		\$0								
Signage and striping (not in contract - in others)	580	LF		\$0								
Sidewalk - concrete	9,280	SF	\$5	\$46,400								
Utilities (gas, water, electrical)	0	LF		\$0								
Drainage (not in contract - by others)	0	LF		\$0								
Sanitary sewer (not in contract - by others)	0	LF		\$0								
Planting and irrigation												
Street trees	1,740	LF	\$14	\$24,400								
Groundplane and irrigation	32,480	SF	\$5	\$162,400								
Street lighting (not in contract - by others)	580	LF		\$0								
Pedestrian lighting	1,160	LF	\$35	\$40,600								
Street furniture	580	LF	\$10	\$5,800								
Monument sign	1	LS	\$15,000	\$15,000								
Canyon Crest Gateway Subtotal				\$295,200								
GAGE CANAL GATEWAY	0 L.F.				340 L.F.				0 L.F.			
Cage Canal cover (not in contract - by others)					340	LF		\$0				
Subgrade preparation					340	LF	\$1	\$300				
Paving (not in contract - by others)					19,040	SF		\$0				
Curb and gutter (not in contract - in others)					1,360	LF		\$0				
Signage and striping (not in contract - in others)					340	LF		\$0				
Sidewalk - concrete					5,440	SF	\$5	\$27,200				
Utilities (gas, water, electrical)					0	LF		\$0				
Drainage (not in contract - by others)					0	LF		\$0				
Sanitary sewer (not in contract - by others)					0	LF		\$0				
Planting and irrigation												
Street trees					680	LF	\$14	\$9,500				
Groundplane and irrigation					9,180	SF	\$5	\$45,900				
Street lighting (not in contract - by others)					340	LF		\$0				
Pedestrian lighting					680	LF	\$35	\$23,800				
Street furniture					340	LF	\$10	\$3,400				
Canyon Crest Mall Subtotal								\$110,100				
Gateways Total				\$295,200	Gateways Total			\$110,100	Gateways Total			\$0

THE GROVE

	Phase One			
	Quantity	Unit	Cost / Unit	Total Cost
GROVE FRAME	1,300 L.F.			
Subgrade preparation	1,300	LF	\$1	\$1,300
Pedestrian paving - concrete	26,000	SF	\$18	\$468,000
Curb and gutter	2,600	LF	\$15	\$39,000
Utilities (gas, water, electrical)	1,300	LF	\$405	\$526,500
Drainage	1,150	LF	\$200	\$230,000
Sanitary sewer	560	LF	\$100	\$56,000
Planting and irrigation				
Trees	2,600	LF	\$14	\$36,400
Groundplane and irrigation	26,000	SF	\$5	\$130,000
Pedestrian lighting	2,600	LF	\$35	\$91,000
Street furniture	1,300	LF	\$10	\$13,000
Wayfinding signage	1,300	LF	\$0.75	\$1,000
Grove Frame Subtotal				\$1,592,200
THE GROVE (up to 75% landscape improvements)	0 S.F.			
Pedestrian paving - concrete				
Utilities (gas, water, electrical)				
Drainage				
Sanitary sewer				
Planting and irrigation				
Trees				
Groundcover				
Pedestrian lighting				
Street furniture				
Wayfinding signage				
The Grove Subtotal				
The Grove Total				\$1,592,200

	Phase Two			
	Quantity	Unit	Cost / Unit	Total Cost
GROVE FRAME	1,740 L.F.			
Subgrade preparation	1,740	LF	\$1	\$1,700
Pedestrian paving - concrete	34,800	SF	\$18	\$626,400
Curb and gutter	3,480	LF	\$15	\$52,200
Utilities (gas, water, electrical)	1,330	LF	\$230	\$305,900
Drainage	0	LF		\$0
Sanitary sewer	480	LF	\$100	\$48,000
Planting and irrigation				
Trees	3,480	LF	\$14	\$48,700
Groundplane and irrigation	34,800	SF	\$5	\$174,000
Pedestrian lighting	3,480	LF	\$35	\$121,800
Street furniture	1,740	LF	\$10	\$17,400
Wayfinding signage	1,740	LF	\$0.75	\$1,300
Grove Frame Subtotal				\$1,397,400
THE GROVE (up to 75% landscape improvements)	471,500 S.F.			
Pedestrian paving - concrete	108,000	SF	\$5	\$540,000
Utilities (gas, water, electrical)	0	LF		\$0
Drainage	0	LF		
Sanitary sewer	0	LF		
Planting and irrigation				
Trees	367,500	SF	\$1.25	\$459,400
Groundcover	367,500	SF	\$5	\$1,837,500
Pedestrian lighting	7,200	LF	\$35	\$252,000
Street furniture	7,200	LF	\$10	\$72,000
Wayfinding signage	4,800	LF	\$0.75	\$3,600
The Grove Subtotal				\$3,164,500
The Grove Total				\$4,561,900

	Phase Three			
	Quantity	Unit	Cost / Unit	Total Cost
GROVE FRAME	0 L.F.			
Subgrade preparation				
Pedestrian paving - concrete				
Curb and gutter				
Utilities (gas, water, electrical)				
Drainage				
Sanitary sewer				
Planting and irrigation				
Trees				
Groundplane and irrigation				
Pedestrian lighting				
Street furniture				
Wayfinding signage				
Grove Frame Subtotal				
THE GROVE (up to 75% landscape improvements)	0 S.F.			
Pedestrian paving - concrete				
Utilities (gas, water, electrical)				
Drainage				
Sanitary sewer				
Planting and irrigation				
Trees				
Groundcover				
Pedestrian lighting				
Street furniture				
Wayfinding signage				
The Grove Subtotal				
The Grove Total				\$0

BUFFERS

	Phase One			
	Quantity	Unit	Cost / Unit	Total Cost
MLK. BLVD BUFFER	0 L.F.			
Ornamental drainage/detention swale (includes pathways, lighting, furnishings, and signage)				
Drainage				
Utilities (gas, water, electrical)				
Planting and irrigation				
Trees				
Groundplane and irrigation				
MLK Jr. Blvd Buffer Subtotal				
FREEWAY BUFFER	0 L.F.			
Planting and irrigation				
Trees				
Groundplane and irrigation				
Gage Canal cover (not in contract - by others)				
Freeway Buffer Subtotal				
Buffers Total				\$0

	Phase Two			
	Quantity	Unit	Cost / Unit	Total Cost
MLK. BLVD BUFFER	3,730 L.F.			
Ornamental drainage/detention swale (includes pathways, lighting, furnishings, and signage)	223,800	SF	\$17	\$3,804,600
Drainage	3,900	LF	\$150	\$585,000
Utilities (gas, water, electrical)	3,900	LF	\$125	\$487,500
Planting and irrigation				
Trees	7,460	LF	\$18	\$134,300
Groundplane and irrigation	149,200	SF	\$3	\$447,600
MLK Jr. Blvd Buffer Subtotal				\$5,459,000
FREEWAY BUFFER	1,230 L.F.			
Planting and irrigation				
Trees	1,230	LF	\$18	\$22,100
Groundplane and irrigation	138,690	SF	\$3	\$416,100
Gage Canal cover (not in contract - by others)	145	LF		\$0
Freeway Buffer Subtotal				\$438,200
Buffers Total				\$5,897,200

	Phase Three			
	Quantity	Unit	Cost / Unit	Total Cost
MLK. BLVD BUFFER	0 L.F.			
Ornamental drainage/detention swale (includes pathways, lighting, furnishings, and signage)				
Drainage				
Utilities (gas, water, electrical)				
Planting and irrigation				
Trees				
Groundplane and irrigation				
MLK Jr. Blvd Buffer Subtotal				
FREEWAY BUFFER	420 L.F.			
Planting and irrigation				
Trees	420	LF	\$18	\$7,600
Groundplane and irrigation	21,000	SF	\$3	\$63,000
Gage Canal cover (not in contract - by others)	0	LF		\$0
Freeway Buffer Subtotal				\$70,600
Buffers Total				\$70,600

UTILITIES - Offsite and special rights of way

	Phase One				Phase Two				Phase Three			
	Quantity	Unit	Cost / Unit	Total Cost	Quantity	Unit	Cost / Unit	Total Cost	Quantity	Unit	Cost / Unit	Total Cost
WATER												
8" line	630	LF		\$0	0	LF		\$0	1,300	LF	\$105	\$136,500
10" line	2,790	LF	\$125	\$348,800	0	LF		\$0	0	LF		\$0
SANITARY SEWER												
8" line	1,830	LF	\$100	\$183,000	0	LF		\$0	0	LF		\$0
10" line	1,640	LF	\$155	\$254,200	0	LF		\$0	1,300	LF	\$155	\$201,500
STORM SEWER												
42" line	740	LF	\$500	\$370,000	0	LF		\$0	0	LF		\$0
ELECTRICAL												
	1,160	LF	\$300	\$348,000	0	LF		\$0	0	LF		\$0
GAS												
	2,030	LF	\$60	\$221,800	0	LF		\$0	0	LF		\$0
	Utilities Total			\$1,725,800	Utilities Total			\$0	Utilities Total			\$338,000

Implementation Elements

Beyond the phasing principles and strategies noted above, there are additional actions that should be taken to assure orderly implementation of the West Campus.

Design Review

UCR will be undertaking an extraordinary building campaign, not only on the West Campus but elsewhere, in order to meet campus growth goals. The pace of construction, on top of ongoing maintenance and renovations that will be required of existing facilities, will inevitably be a strain. It will be important throughout this process, however, to maintain the highest standards of design quality. The West Campus represents an extraordinary opportunity for UC Riverside.

Regular review of individual projects should occur throughout the implementation of the West Campus. This can be greatly aided with the assistance of a Design Review Committee. Comprised of representatives of the campus as well as outside experts (designers and planners), the Design Review Committee, properly composed, will assist in guiding design, and in interpreting and where necessary redefining the guidelines, principles and plans included in this West Campus Area Plan. Such design committees are in place on other UC campuses.

Ongoing Community Participation

Involvement of a range of campus constituents in the ongoing design and implementation of the West Campus is also important. Whether in the context of the Design Review Committee or in other roles, students, faculty and staff should be provided with meaningful roles in the implementation of this plan. Public art, demonstration and educational gardens, event programming, and historical markers and walks are all ways that a wide constituency of the campus can be involved in the creation of the West Campus.

Alumni and Development Opportunities

There will also be numerous opportunities to involve alumni and other potential donors in development of the West Campus. The Grove in particular represents

a unique opportunity to capture interest and funds for the implementation of a feature that will celebrate the history and legacy of the Riverside campus as a cultural, educational, and research center in California's Inland Empire.

Other Plans

This West Campus Area Plan has been prepared based on the plans, policies and guidelines embodied in the 2003 Long Range Development Plan for UCR. The Strategic Plan for Housing, completed concurrently with this plan, is also reflected in relevant plans.

Planning will be ongoing at UCR and other plans can provide supplemental guidance for development of the West Campus. An example of such a plan would be the Transportation Plan and Program, currently in development by the campus.



DESIGN GUIDELINES

DESIGN GUIDELINES

Introduction

During the next several decades, UCR is projected to grow significantly to accommodate a near doubling of campus population. As discussed earlier in this document, much of this new development will occur on the West Campus.

The design of the West Campus presents important opportunities for UCR. As the campus expands to the west, where few buildings currently exist, there is an opportunity to establish a new image, related to but distinct from the context of the East Campus, that was primarily built in the mid- to late-20th Century. Therefore, the new buildings and landscape of the West Campus have two responsibilities:

- To create an identifiable new campus environment, and
- To maintain a visual relationship with the East Campus.

At the same time, site design and architecture must be responsive to program, environment, and physical, institutional, and social context.

The guidelines that follow are intended to provide direction for the siting and design of buildings, and for the design of landscape improvements on the West Campus. In combination with policies articulated in the 2003 LRDP, it is intended that the criteria outlined in this section will lead to the design and construction of buildings and landscape that in and of themselves will teach and inform students and visitors about UCR, the region, and the importance of the environment, both built and natural.

Design Principles

The layout and design of the West Campus has been informed by four major design and planning principles that are manifested in the plan layout and in the guidelines that follow.

Sustainable Design and Planning

The 2003 LRDP identifies policies to achieve standards of sustainability in the planning and design of UCR. The West Campus can be a model of these strategies. It is intended that building siting, design and relation to the surrounding landscape, as well as the design of infrastructure components be responsive to area climate and context and sustainable practices.

Pedestrian and Bicycle Access

As directed by the 2003 LRDP, as UCR grows a greater emphasis will be placed on promoting the use of alternatives to the automobile, in particular the use of bicycles and transit. In addition, the generally benign climate of the region allows comfortable walking nearly year round. The pedestrian environment is of primary importance; the design of buildings and landscape improvements are intended therefore to contribute to an attractive and comfortable pedestrian and bicycle environment.

Landmarks

The physical extent of UCR will make wayfinding more challenging, in particular for visitors. As a consequence, the design and siting of certain buildings will contribute to the creation of special landmarks that stand out on the horizon and lead pedestrians to important destinations. Buildings and landscape improvements will create a coherent campus environment, but one that allows for special buildings, structures or places to emerge as landmarks.

Regional Design Influences

The design of the site and buildings on the West Campus will respond to the context of the region, in particular the rich history of citrus cultivation and research. At the same time the character of the West Campus will be clearly related to the context and existing character of the East

Campus, and be of an appropriate institutional nature.

As described below, it is the intent that the design of the West Campus be influenced by two distinct but interrelated influences: "Citrus Agriculture " and "Townscape."

Citrus Agriculture

Citrus agriculture differs from the common image of American agricultural iconography. It is an environment where the dominant physical forms tend to be the agricultural elements themselves: namely, the grid of orderly rows of citrus trees, individual specimen trees marking entries or landmarks, and rows of trees - often tall palms - along the horizon, marking roads and property boundaries. Architectural elements are seldom dominating forms. The fundamentals of the forms found in citrus agriculture can guide the design and site planning of the academic area of the West Campus.

The citrus agriculture building complex typically lies at some distance off a narrow public right-of-way. A cluster of buildings is typically found either directly adjacent to the road or down a narrow farm road. The farm house is usually encountered first, its architecture often of a modest Victorian formality with an elevated first floor porch and encircling veranda. Behind the house are clustered the functional buildings - warehouses, sheds, garages, etc. - set around a service yard. To all sides of this ensemble, oriented in neat and serviceable rows, are the citrus groves. This clustering of buildings is particularly appropriate for those special facilities that will be sited in The Grove. The porches and verandas are useful design elements for all buildings in or adjacent to The Grove.

Buildings are typically of a modest scale in the citrus agriculture environment. However, taller elements include windmills and water tanks, as well as monumental trees. In the West Campus the juxtaposition of a few taller elements with prevailing lower buildings will assist in orientation.

From a historical perspective there is no dominant indigenous building style associated with the citrus heritage of the Inland Empire. However, two models from other locations were adopted locally:

Figure 38 Agricultural buildings are secondary in appearance to the dominant surrounding agricultural landscape



Figure 39 The UCSC Student Center is an example of a special building of a scale and character that might fit well in The Grove.



Figure 40 The architectural design of the new Humanities complex utilizes shapes, materials and an overall organization that is reminiscent of agricultural buildings.



- The Victorian domestic building with porch and veranda described above.
- Mission Revival, often with a central courtyard. The AGSM building (one of the original Citrus Experiment Station buildings) on the East Campus is of this style as is the Mission Inn in downtown Riverside.

The porch and veranda of the Victorian, and the courtyard of the Mission Revival style are both well suited to the Riverside climate, and to the citrus heritage of the West Campus.

Its local abundance and ease of use make wood particularly common in the historical architecture of California's citrus regions. Metal is equally common, often used for cladding where it is typically found as corrugated sheets. Masonry, stucco and stone are also historically found in the citrus regions of California. All of these materials may have applicability for the building types that will be found in the academic areas. While a sense of permanence is important for university buildings, the wealth of appropriate materials can lend a special character to the West Campus.

It is intended that these characteristics of the buildings and landscape of the historic citrus landscape of Riverside serve as a guide for the design of buildings and landscape improvements within the academic core of the West Campus, particularly in areas directly fronting and adjacent to The Grove.

Townscape

Citrus agricultural regions have two distinguishing domesticated environments. One is the cultivated landscape - UCR's Citrus Heritage. The other is the adjacent city or town. These urbanized areas provide the services and cultural amenities required by the outlying farms and groves. These towns typically are of moderate density and, historically, were of compact size. Before suburbanization, the seam between town and grove was clear: it was the place where the compact grid of streets and blocks expanded into the grid of country roads and citrus groves. The residential and commercial areas adjacent to the West Campus on the north and west are built along this more urban framework of tree-lined streets and blocks. The new West Campus residential areas will be developed following this model.

The residential townscape of the West Campus is primarily a pedestrian friendly environment modeled on a traditional town. Site planning and landscaping will provide a setting that makes walking between destinations enjoyable and desirable. Streets will be narrow and will be dominated by rows of shade trees and sidewalk parkways. Building entries will face the street and will be set back from the right of way enough to allow for small front yards. There will be no privacy walls separating buildings from the street. Some cars will park at the curb, with others stored behind the buildings in inner-block lots and garages. Neighborhood parks will be dispersed at regular intervals, and will be accessible from the streets and pedestrian mid-block pathways.

Architecture must contribute to and reinforce this environment with appropriate scale, massing, materials, and features. Residential buildings will be secondary to the landscape, providing a subtle background framework for public space. Local community-serving buildings, such as the child development center or recreation facility, may take a more prominent, landmark role.



Figure 41 New apartment housing on the East and West Campuses should include similar features as this example, such as entries from the sidewalk, minimum setbacks, and balconies and windows facing the street to contribute to a sense of neighborhood.



Figure 42 New family housing on the West Campus will orient around neighborhood parks, providing a recreation resource and centerpiece for the neighborhoods.



Figure 43 Narrow streets within the family housing areas of the West Campus will slow traffic and improve pedestrian safety. Shade trees will contribute to a comfortable outdoor environment.

Academic Area Guidelines

Site Planning

The academic core area of the West Campus will be the focus of instructional and research activities associated with graduate and upper division undergraduate curricula and the professional schools.

In order to support the long term development of a clear image for the West Campus, certain basic site planning guidelines need to be followed. These guidelines will help establish the fundamental structure of the West Campus, into which individual buildings and landscape will fit.

Following are general site planning guidelines for the academic core of the West Campus. They address the following topics:

- Building types
- Build-to lines
- Special buildings
- Primary building entries
- Building porches, verandas and arcades
- Focal points and axes

Figure 44 Building Types

Building Types

There are five basic building types in the West Campus academic area. These building types will all contribute to the total West Campus environment, while satisfying their own unique requirements.

Inner Grove Buildings

This special group of buildings should be most evocative of the citrus/agricultural heritage. Buildings located in the Grove should be of a campus-wide nature, attracting students, faculty and staff, such as a student commons, dining hall, meeting rooms, library, etc. The Grove should not be filled with buildings. Rather, areas of The Grove should be set aside for special event venues, art installations, and shaded informal seating and relaxing areas.

Grove Frame Buildings

Buildings surrounding The Grove shall be prominent, monumental, and institutional. They should achieve an architectural consistency, without rigid uniformity and display characteristics that also relate to their location adjacent to a symbol of UCR’s citrus/agricultural heritage. Special design considerations apply to building along the Grove Frame.

Entry Buildings

Entries to West Campus must provide a welcoming and memorable environment. They must also provide a transition between the public “outside” environment and the academic core. Consistent architectural elements will assist imageability and way finding.

Background Buildings

Buildings located off of primary pathways and open spaces have more opportunity to deviate from the consistency required of The Grove Frame and Entry Buildings.

Structured Parking

These buildings have a greater campus responsibility than simply warehousing cars. They must also contribute to pathways and public spaces with pedestrian friendly facades, appropriately placed vehicle and pedestrian access points, and maximum heights that are lower than predominant buildings.

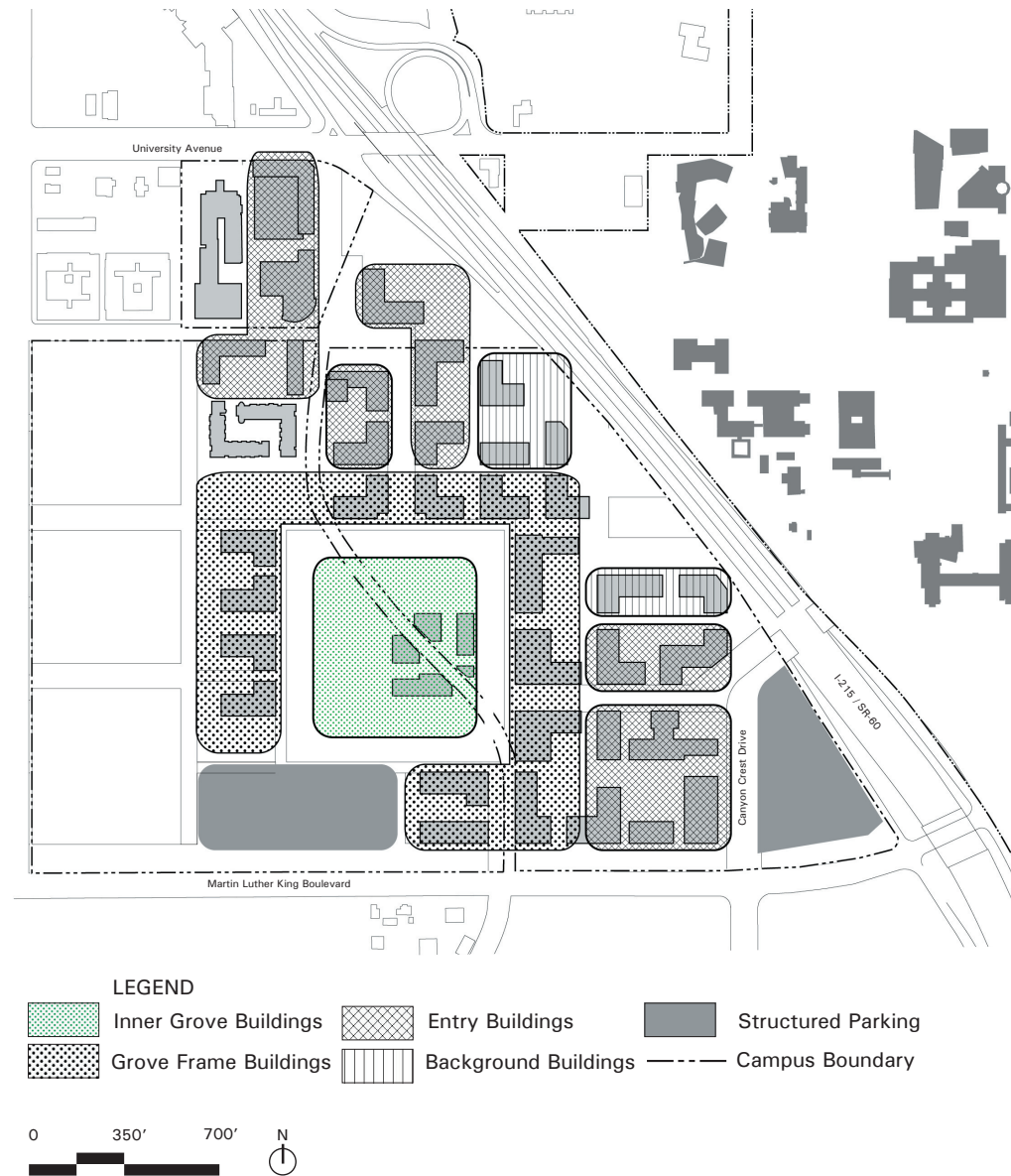
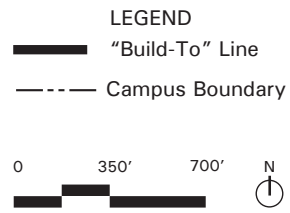
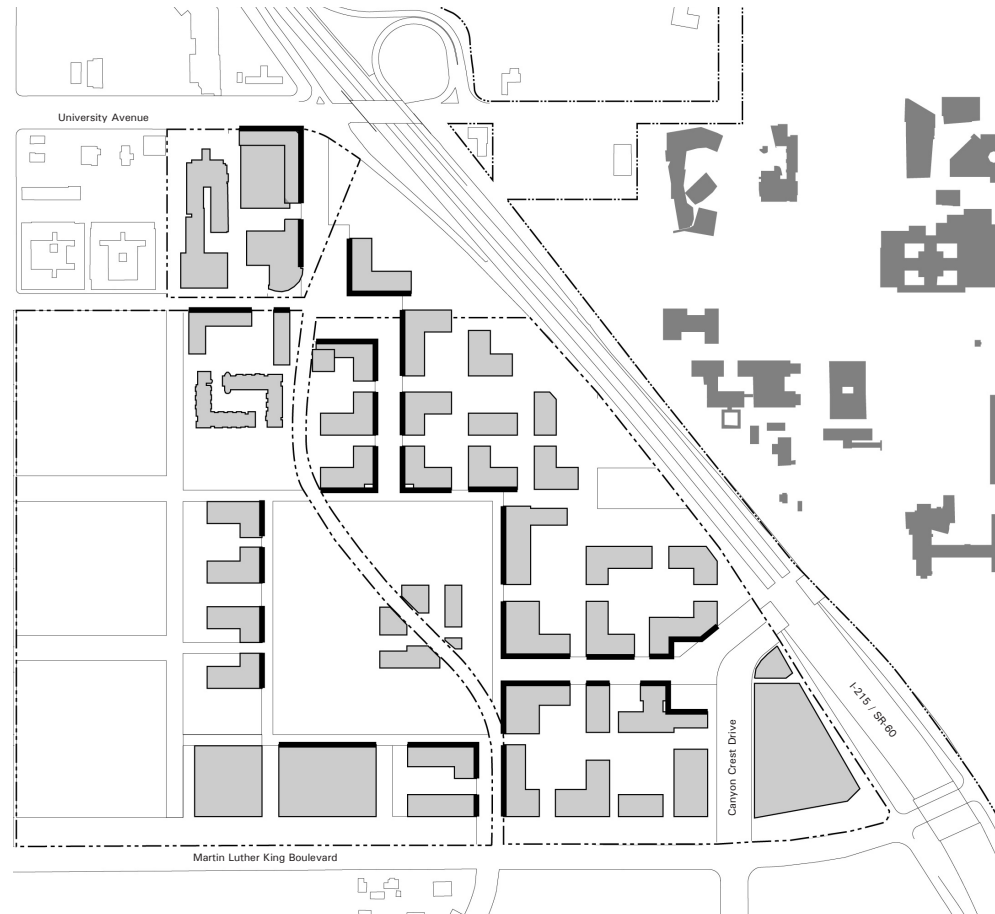

Figure 45 Build To Lines



Build-To Lines

Build-to-lines establish the location and orientation of primary building facades to assure that the appropriate level of enclosure is provided for important open spaces. Buildings surrounding four primary public spaces of the West Campus academic core must be placed along consistent build-to lines, to create a frame to reinforce and define the open spaces. These four open spaces include The Grove, University Mall, Canyon Crest Mall and the Gage Canal Gateway.

Building programs at these locations must be adequate to create a building of sufficient size to fill the build-to-line area. Building footprint behind the build-to-lines can vary according to program and other site requirements.

Figure 46 Special Buildings

Special Buildings

Special West Campus buildings will occupy prominent sites that will visually dominate major pedestrian corridors. These buildings are located at entry points, the end of an axis, on important corners, or in/on major public spaces such as The Grove. These sites present opportunities for landmark buildings that will reinforce the memorable public image of West Campus architecture. (See also the Axes and Focal Points section.)

Special buildings within The Grove and along University and Canyon Crest Malls will be programmed for facilities that have high levels of use by the entire University community. These might include libraries, dining halls or student commons.

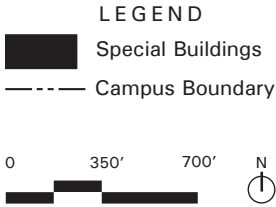
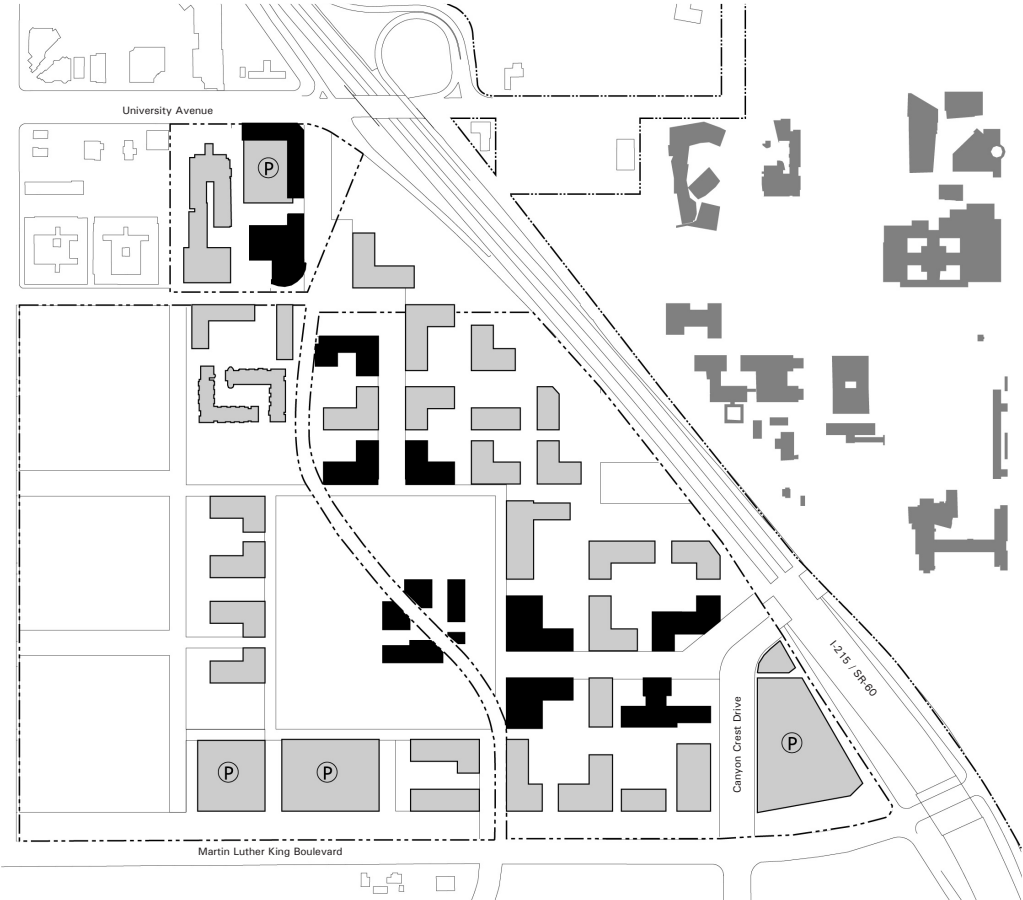
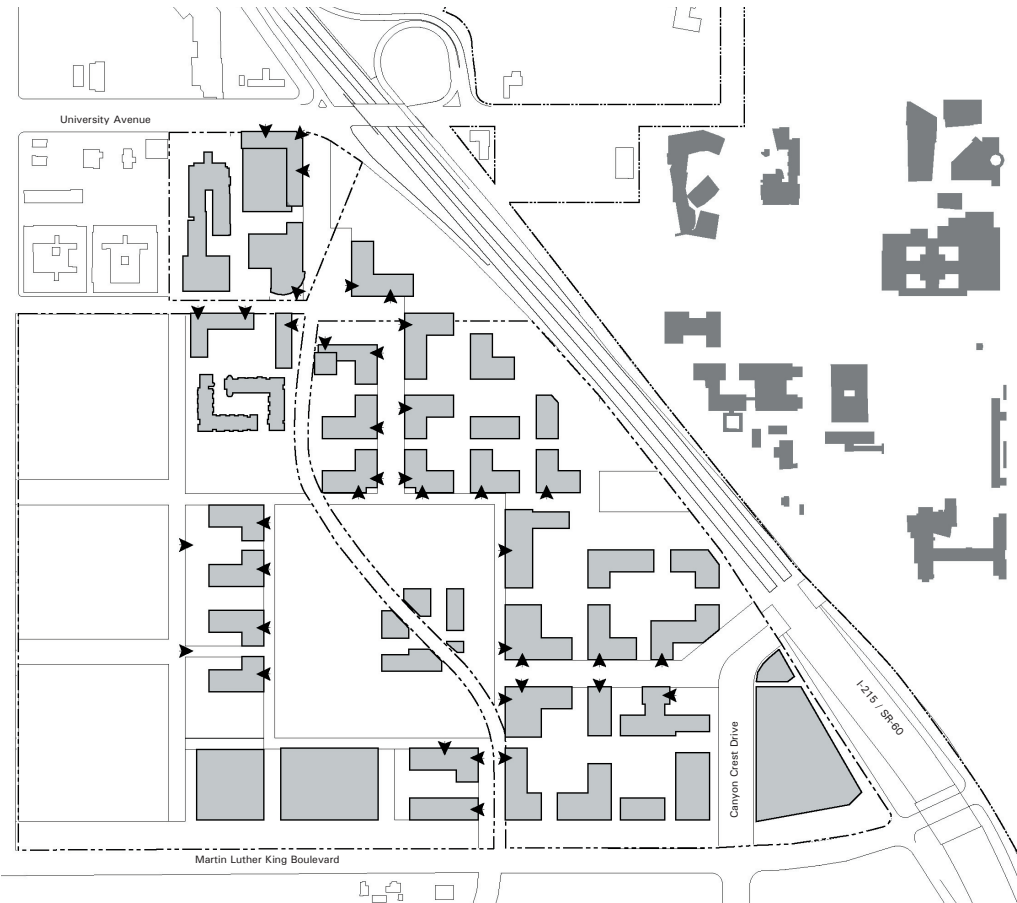

Figure 47 Primary Building Entry



LEGEND

- ▲ Major Building Entries
- Campus Boundary



Primary Building Entries

It is desirable to have primary building entries located at areas of intense pedestrian activity. Properly designed entry areas with porches, atriums, arcades and loggias offer opportunities for informal gathering and meeting among campus students, faculty and staff.

Primary building entries must be located to complement the primary pedestrian corridors of the West Campus academic core. In early years this will help ensure a sense of activity as the West Campus develops. Figure 47 illustrates conceptually the intended general locations and orientation of building entries.

Primary entries generally correspond to build-to-line facades of major malls and public spaces of the West Campus. These entries occur along the primary building facade, typically located on an adjacent primary public space. The primary building entry should be expressed through special articulation of the building, including facade, roof articulation or other special elements.

To further reinforce the pedestrian corridors and building entries, active uses associated with any building, in particular uses such as cafes, should be adjacent to the entry and easily visible and accessible.

Figure 49 Building Porches, Verandas, and Arcades

Building Porches, Verandas and Arcades

Elevated porches and verandas were common features of citrus agricultural environments, offering shade, social space, a viewing point for looking out over the surrounding groves, and building entries. Porches and verandas also create a continuous architectural feature that can be used to recall the UCR citrus heritage, aid wayfinding through campus, and denote the major entry to a building.

Elevated porches or verandas should be part of all academic buildings facing The Grove extending across the full width of the façade and potentially wrapping additional sides of the building. The porch and veranda will face the Mall and The Grove in a relatively formal fashion and overlook the surrounding groves. It is not intended that these elements be expressly historic; rather, that they achieve the functional criteria of continuity and protection.

Arcades should be located along both primary West Campus entry malls – University Mall and Canyon Crest Mall. Arcades should be no more than two stories in height. Arcades may be at grade level or higher and may be additive or recessed.

Figure 48 Building Porches, Verandas, and Arcades Illustrative Cross Sections

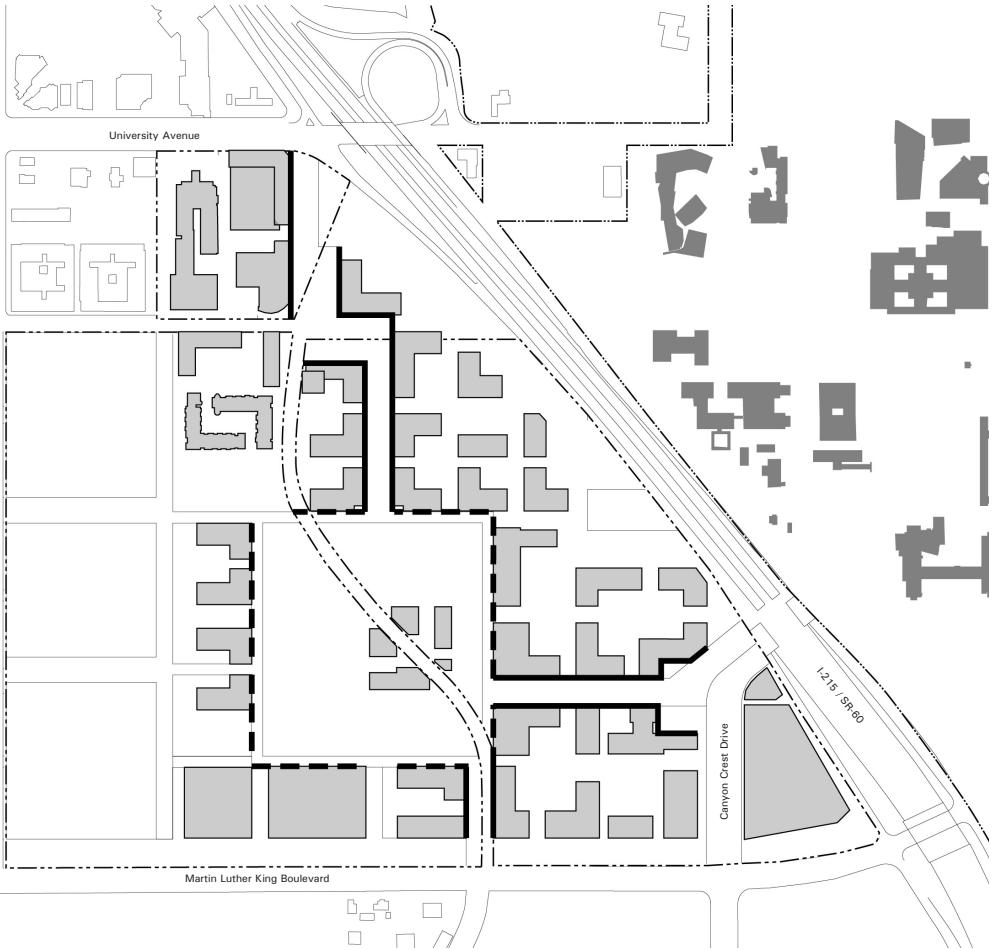
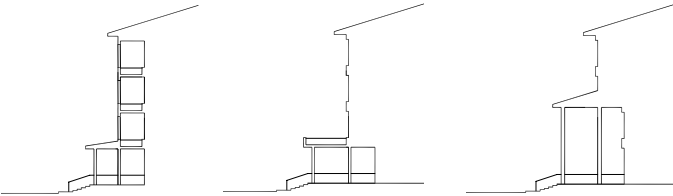

LEGEND

- Building Arcades
- Building Porches and Verandas
- Campus Boundary

0 350' 700' N

Figure 50 Focal Points and Axes

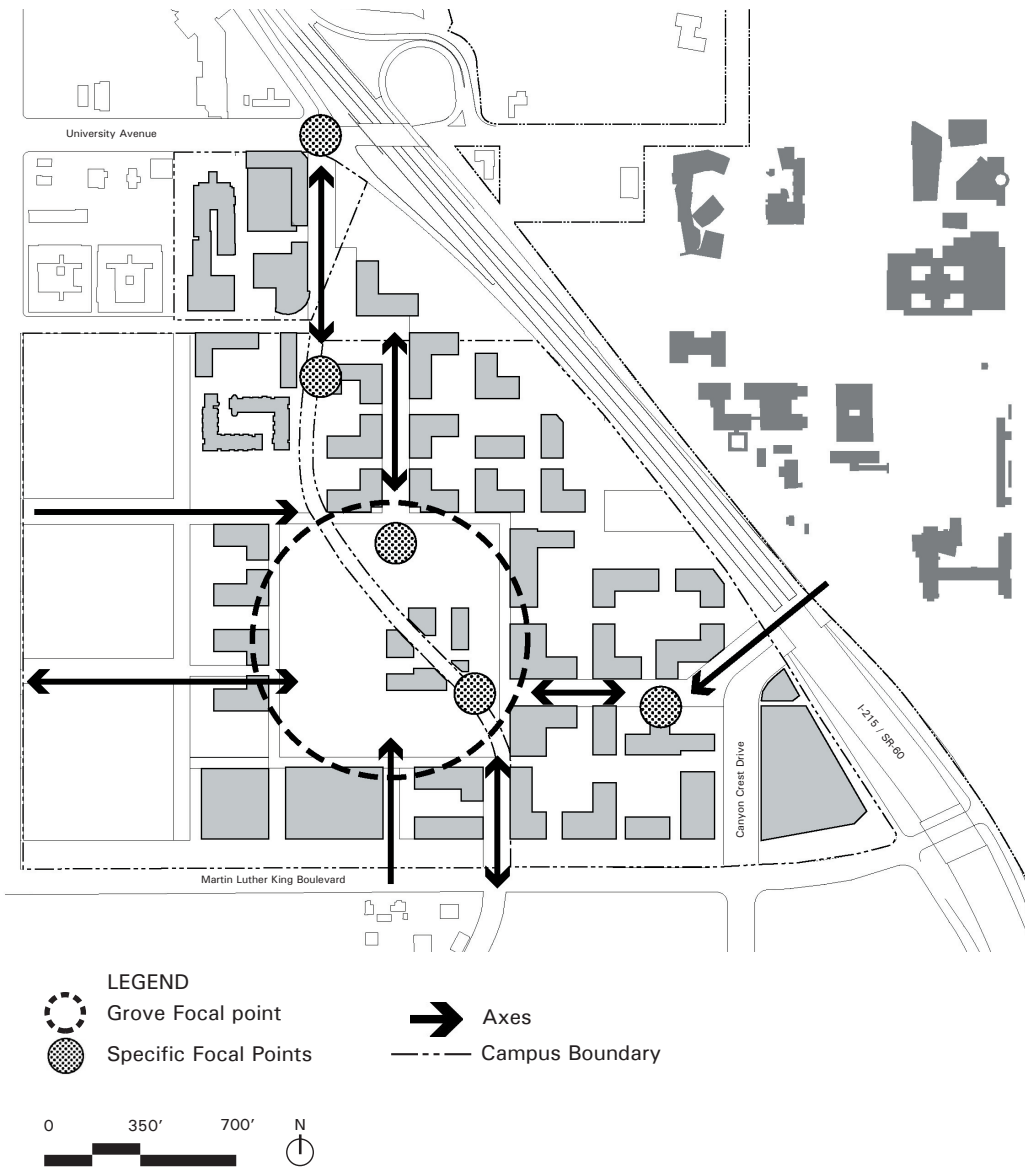

Focal Points & Axes

The grid framework of the West Campus sets up visual axes and focal points within the overall building fabric. The axes provide a clarity of orientation within the area. Landscape and building improvements can reinforce the axial nature of the view without unnecessarily blocking or obscuring it.

Within the framework of the academic core, several West Campus building sites gain prominence by their location at the end of significant visual corridors or along key routes. These focal point sites offer opportunities for the design of landmark structures or landscape improvements that will help in general orientation and wayfinding, and will also provide a visual punctuation within the academic core building fabric. Some sites also provide important views to central public spaces such as The Grove.

Figure 51 Academic Districts
and Special Building
Overview



Academic Districts & Special Buildings Guidelines

Figure 51 illustrates sub-areas within the West Campus academic core area. These sub-areas or districts are illustrated and further described in the pages that follow.

Each district plays a role in the overall organization and legibility of the West Campus area. Within the district, some buildings contribute to the overall site framework and others, as described previously, are either special use or landmark buildings. All buildings in a district need to observe certain rules in order to assure an orderly and legible campus area.

The following diagrams illustrate possible solutions to specific building sites, but are not intended to imply a limitation on design solutions; rather they are intended to communicate the general design intent that buildings within a specified sub-district should display in order to contribute to the overall vision for the West Campus.

Figure 52 The Grove District

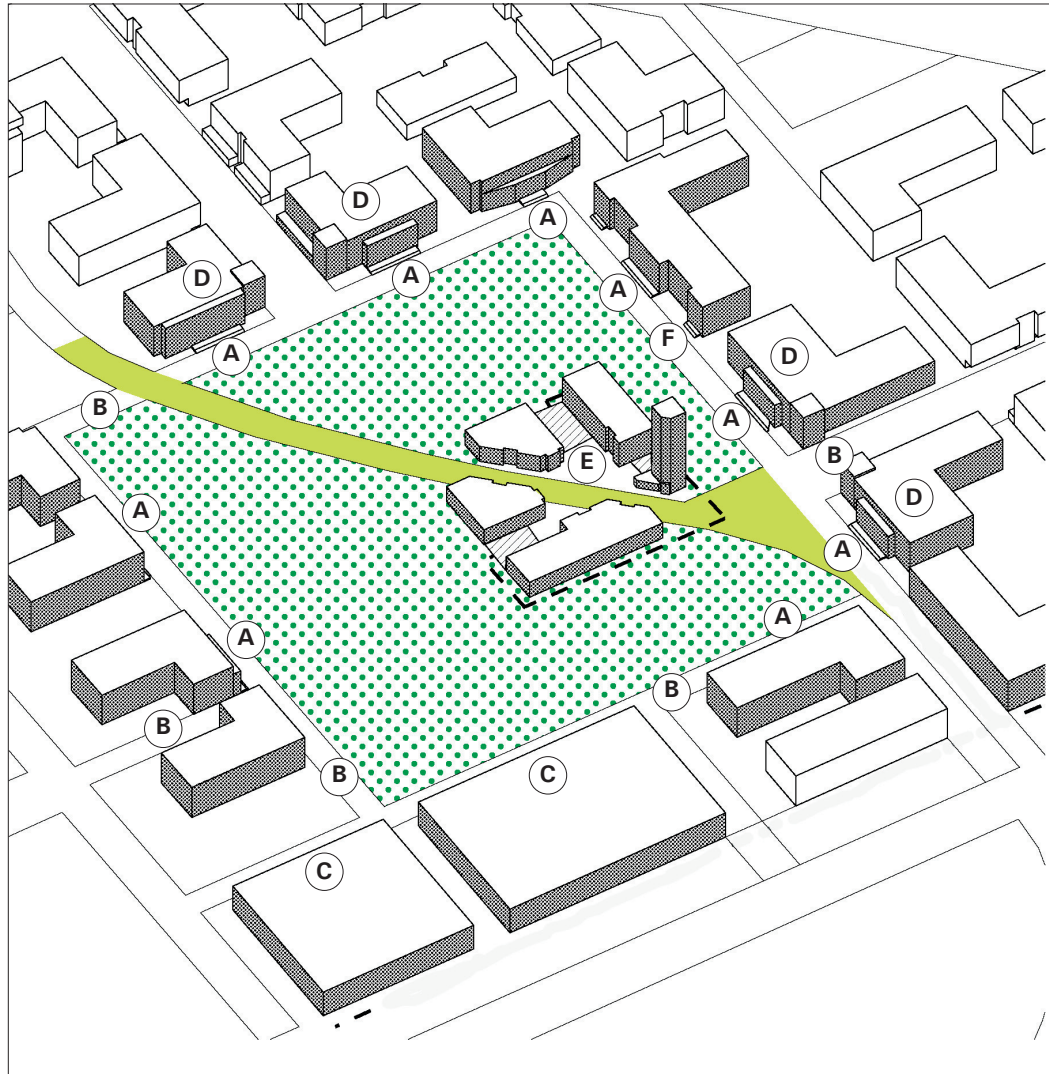

LEGEND

- Gage Mall
- The Grove
- Service court

The Grove District

The Grove District lies in the heart of the academic core and is the signature open space for the West Campus. Buildings of particular importance and uses of campus-wide interest should be located in The Grove District, thus ensuring a continually active campus environment.

Buildings in The Grove District, while of an institutional nature, provide an opportunity to reflect the citrus heritage of the campus and of the Riverside region. Buildings may be built throughout the inner portion of The Grove, respecting the 100-foot setback from the edge or Grove Frame, allowing for a constant frame of plantings. Buildings should be clustered, as illustrated in the accompanying diagram, to create activity areas. In locating buildings inside The Grove, particular attention should be paid to ensuring that the visibility of all walkways and areas of The Grove can be assured.

- A. The Grove Frame: The 40 foot wide Grove Frame provides a shaded pedestrian path around The Grove and an address for the academic buildings. Primary entries of buildings facing The Grove should be raised above prevailing grade, with an entry porch or a veranda across the entire facade.
- B. Visual connections into The Grove should be provided on axis with local streets and pedestrian malls and gateways.
- C. Parking structures adjoining The Grove must provide a 15' min. landscape setback from The Grove Frame walkway.
- D. Buildings adjoining The Grove at Canyon Crest Mall and University Mall should mark and accentuate these prominent intersections, and may incorporate a taller element at the corners. These building sites should be reserved for prominent and/or active uses (such as a library).
- E. Inner Grove Buildings (see following page).

Figure 53 Inner Grove Buildings

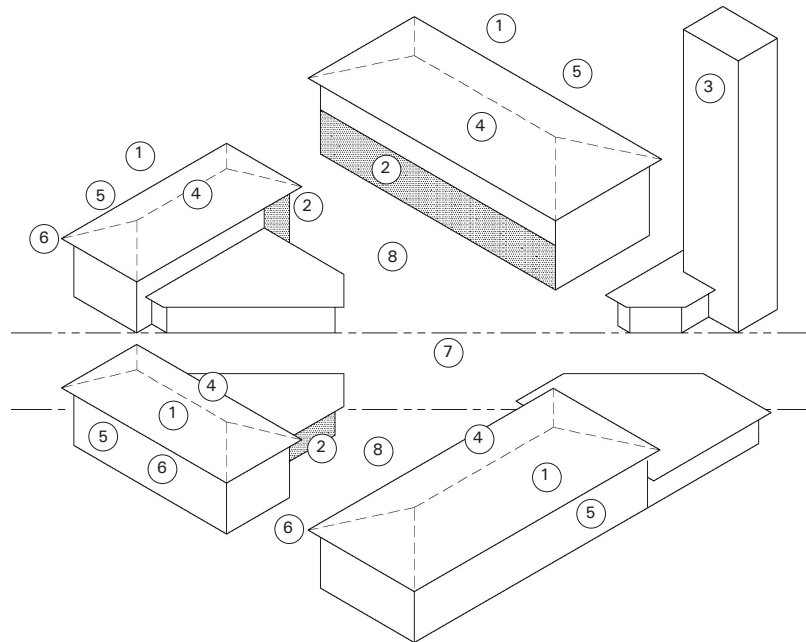

F. Inner Grove Buildings

These buildings should be unique campus structures, appropriate to their special location within The Grove. Heights should be limited to two or three stories, with the exception of a tower element that may be higher to serve as a landmark for the entire West Campus, similar to the Carillon Tower on the East Campus. Building entries should be off courtyards; service entries are not accessed from Gage Mall, but rather from the periphery of the building complex.

The illustrative arrangement of buildings is based on a typical cluster of functional agricultural buildings set around a service yard and surrounded by citrus groves. As the heart of West Campus within The Grove, this ensemble of buildings should be a meeting place for the entire West Campus and contain uses such as a common, food service, and meeting and activity spaces.

1. Limit building height to two or three stories.
2. Reserve ground level for public and active uses on the courtyard side. Provide visual transparency into ground level interior spaces from adjacent public spaces.
3. Tall landmark structure or building. This structure should visually orient pedestrians and be an identifying element for the West Campus.
4. Screen rooftop mechanical equipment and incorporate into building roof.
5. Provide service access from the outside perimeter.
6. Provide large roof overhangs to cap building volume and contribute to sun shading.
7. Maintain the pedestrian/bicycle service corridor along Gage Mall.
8. Provide adjoining courtyards for outdoor seating, gathering and activities.

Figure 54 University Mall District

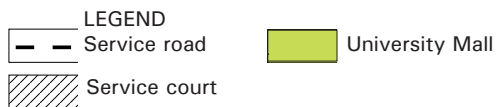
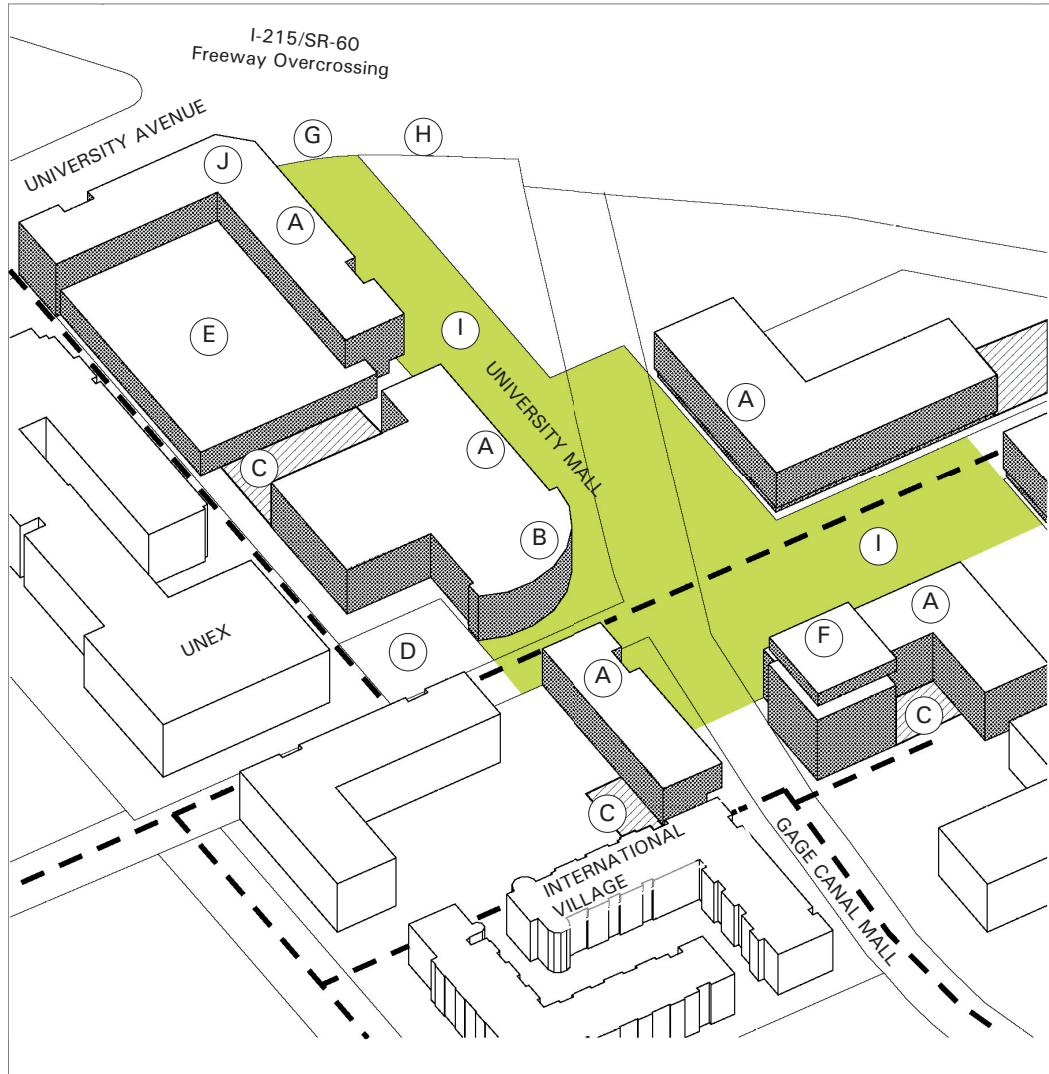

University Mall District

University Mall lies immediately south of University Avenue and is the primary entry into the West Campus academic core from the north and northeast. This district must establish a generous visual corridor into the academic area. Buildings that front this corridor must be particularly supportive of an active pedestrian environment. This district is a possible site for a conference center associated with UNEX.

- A. Primary building entries should be aligned to face University Mall.
- B. Buildings located at the intersection of Everton Place, University Mall, and Gage Canal Mall may include a prominent corner/architectural element.
- C. Service courts and service routes should be aligned to minimize interference with important pedestrian and bicycle routes.
- D. A vehicular turn around and drop-off for University buildings, particularly UNEX and any future conference/hotel facilities would occur from Everton Place.
- E. Parking for the UNEX complex would occur in a 3-story structure, with access via Everton Place and the alley off University Avenue.
- F. The building at the visual terminus of University Mall should serve as a landmark, orienting device, possibly with a taller element.
- G. The entrance to University Mall at University Avenue is a critical pedestrian gateway from the East Campus and should be wide and welcoming, generously landscaped with amenities and active ground level uses in adjacent buildings, including retail wherever possible.

Figure 55 University Avenue Mixed Use Building

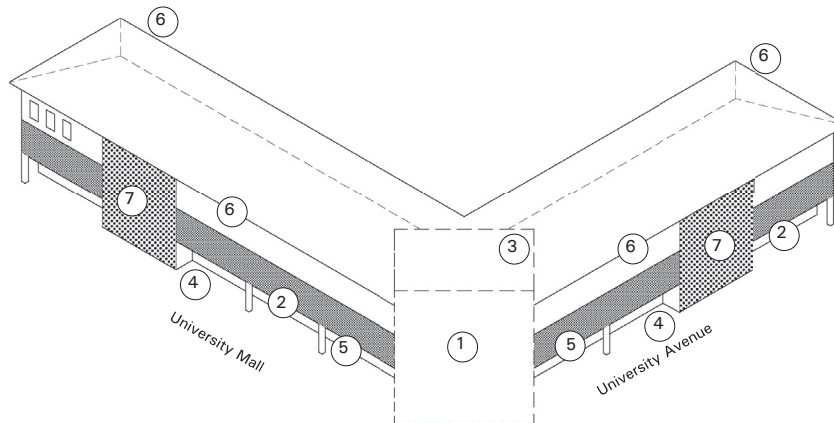

- H. Coordinate with Caltrans to reduce the width and realign the freeway on-ramp to improve pedestrian crossings to University Mall from the East Campus.
- I. A special plaza or open space may occur at the juncture of University Mall and the extension of Everton Place.
- J. **University Avenue Mixed Use Building** - 4-story mixed-use building with ground floor "active uses" including retail. This building should extend the character of the West Campus academic buildings to the University Avenue environment (see detailed building guidelines - opposite).

This building is planned as a mixed use building with strong public programming such as a portion of a University conference center or a hotel wing. Its location and design should be visible from the freeway and provide definition and activity along University Avenue. The building should also extend the character of the West Campus academic buildings to the University Avenue environment.

1. Articulate building corner to serve as a landmark feature, and primary building entry, and to create an enhanced visible pedestrian destination when coming from East Campus.
2. Provide an articulated building base.
3. Roof volumes may contribute to accentuating primary building entry.
4. Reserve ground level for public and active uses such as retail and active student services. Provide visual transparency into ground level interior spaces from adjacent public spaces.
5. Provide ground level arcades on University Avenue and University Mall facades.
6. Provide large roof overhangs to cap building volume and contribute to sun shading; screen rooftop equipment.
7. Articulate secondary building entries.

Figure 56 Gage Mall District

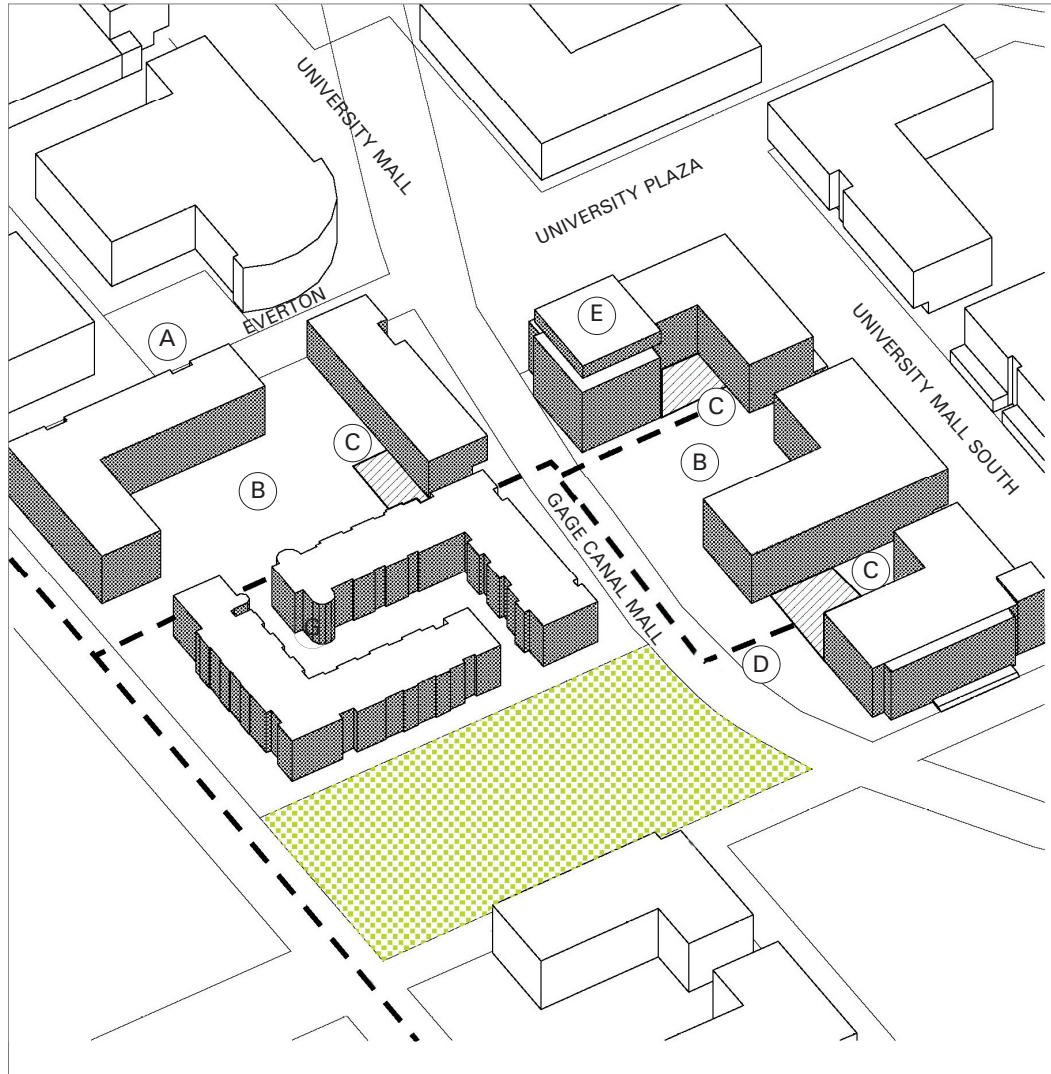

LEGEND	
	Service road
	Service court
	Existing recreational open space

Gage Mall District

The Gage Mall District lies immediately south of the University Mall and provides a transition into the The Grove District. It includes the existing International Village Housing, and includes a portion of Gage Canal Mall (located along the alignment of Gage Canal, to be covered).

- A. Buildings located on Everton Place should have their primary entry from that street.
- B. Buildings in this area may include interior shaded courtyards. They should readily connect to Gage Canal Mall and University Mall South.
- C. Building loading docks and service courts should be screened from view and consolidated to the degree possible.
- D. Service access can be provided from the Gage Mall right of way as well as the road running north/south that lies to the west of this district. However, service roads should avoid heavily traversed pedestrian corridors such as Gage Mall and University Mall to the extent possible.
- E. North Entry Axis Building (see following page).

Figure 57 North Entry Axis Building

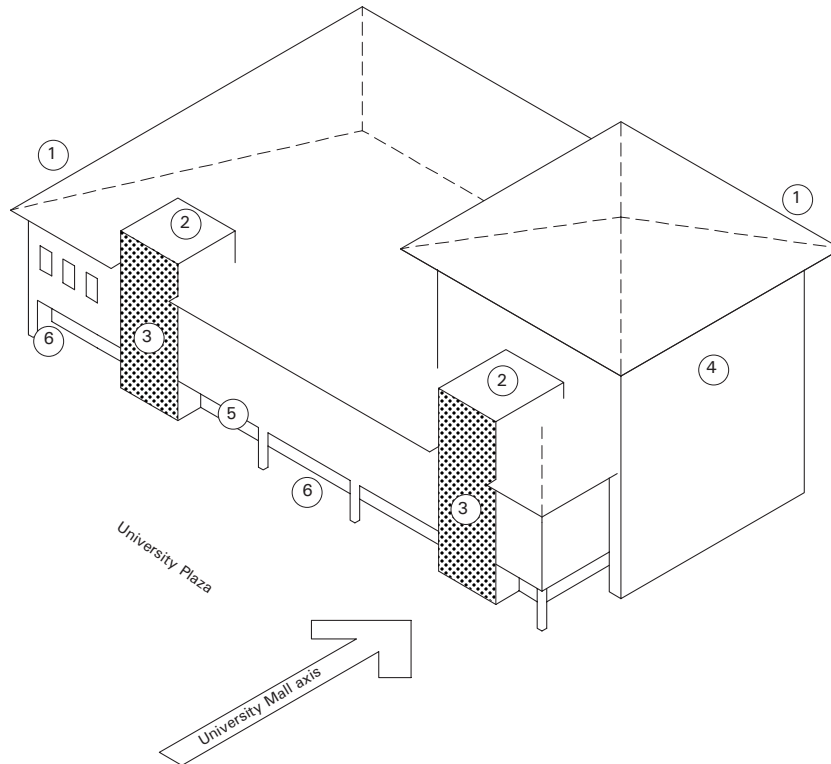

E. North Entry Axis Building

This building should address and terminate the visual axis leading from University Avenue along University Mall. A tower element can be used to punctuate this view and provide orientation and a landmark.

1. Provide large roof overhangs to cap building volume and contribute to sun shading.
2. Screen rooftop mechanical equipment and incorporate into building roof architecture. Rooftop volumes may contribute to accentuating primary building entries.
3. Articulate primary and secondary building entries for ease of wayfinding. The primary entry should be on axis with University Mall.
4. Provide a tower element or special space to terminate the North University Mall axis.
5. Provide an articulated building base.
6. Provide a ground level arcade on University Mall facades.

Figure 58 Canyon Crest Mall District

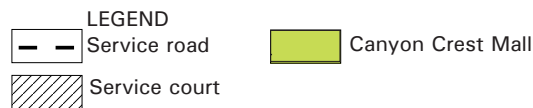
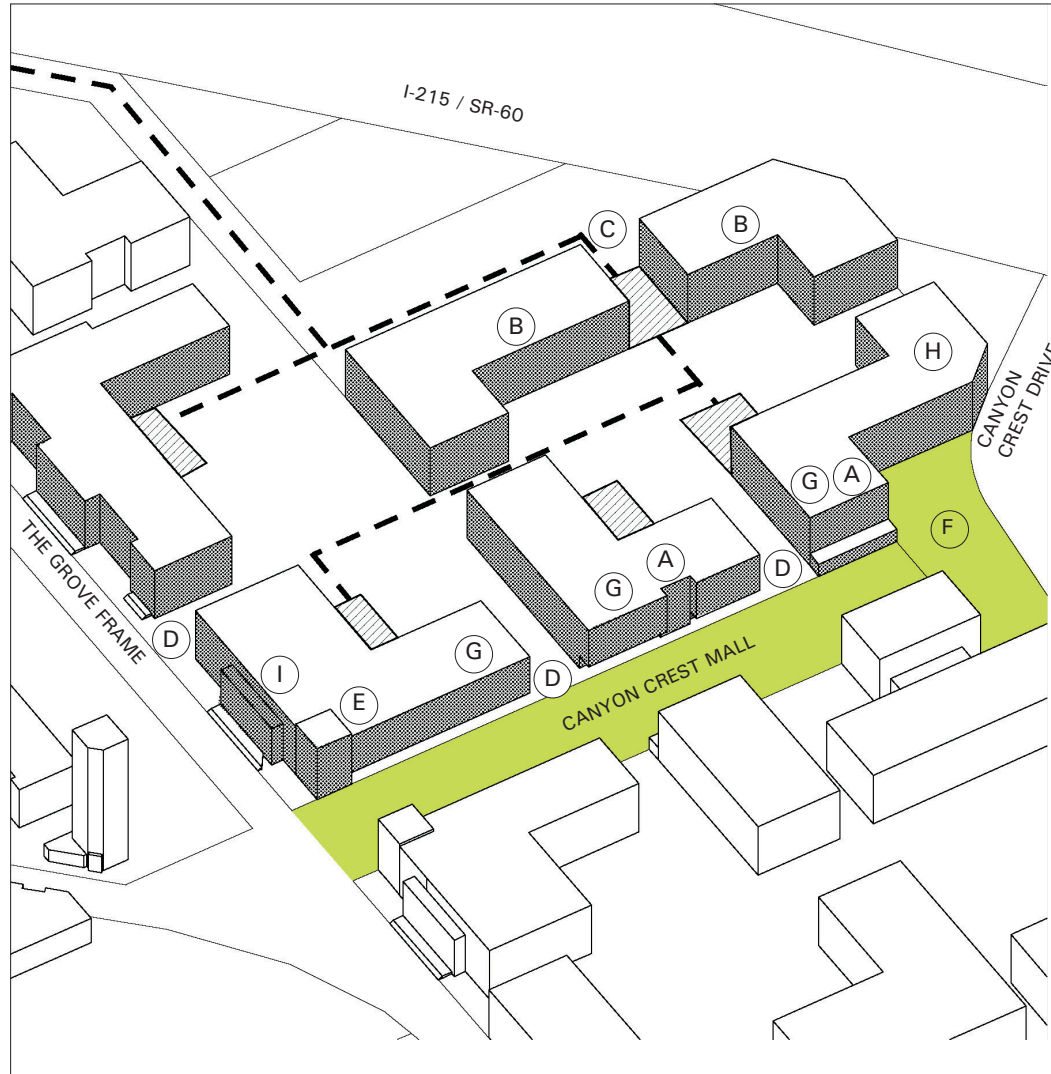

Canyon Crest Mall District

The Canyon Crest Mall District is aligned along the north side of Canyon Crest Mall leading into the West Campus from the Canyon Crest undercrossing. Like the University Mall District, buildings along the mall must reinforce the importance of this Mall as a connection to the East Campus. Buildings should also emphasize its axially and landscaping of the Mall should focus views toward The Grove. Active uses and primary building entries must also locate along this corridor.

- A. Building entries should be located on primary open spaces and articulated to aid in wayfinding.
- B. Interior buildings should be entered from shaded internal courtyards, linked to Canyon Crest Mall.
- C. Service areas should be provided away from primary pedestrian routes. Access to these service areas should be provided via service roads that avoid areas of heavy pedestrian activity.
- D. Secondary pedestrian malls or connections should be provided into the interior courtyards from Canyon Crest Mall and The Grove and Grove Frame.
- E. The intersection of Canyon Crest Mall and The Grove and Grove Frame is an important address. These buildings should house important uses. Building design can articulate the corner or otherwise serve as landmarks and aids in orientation and wayfinding.
- F. A major plaza - Canyon Crest Plaza - should be provided at the intersection of Canyon Crest Mall, with the Canyon Crest Undercrossing. This will be a major connection between East and West Campuses with uses such as food service. Design of the plaza can help minimize the perception of distance between the two parts of UCR.
- G. Continuous arcades on all Canyon Crest Mall facades will provide shade and visual continuity.

Figure 59 Grove / East Entry Building

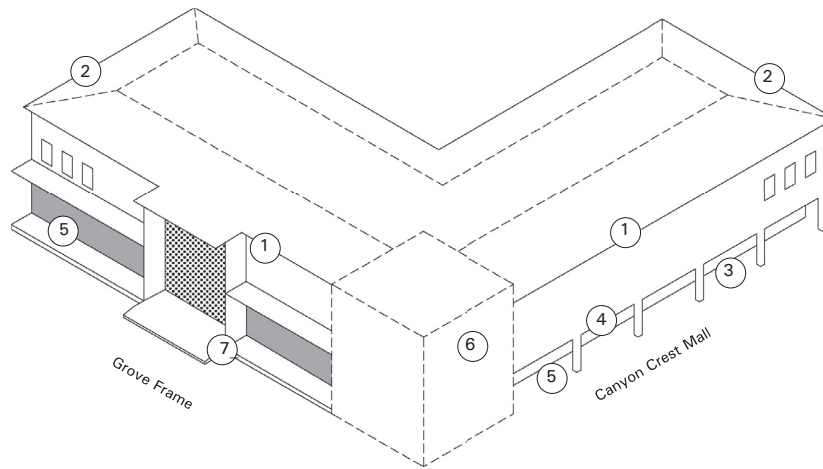

H. The building at the eastern terminus of the Canyon Crest Mall should acknowledge the visibility of this location. Building facades should frame this open space, and create a scale campus space that promotes gathering and activities. Retail and food service may be located in this building.

I. Grove East Entry Building

This building should mark and accentuate the prominent intersection of The Grove Frame and Canyon Crest Mall and should be reserved for a highly active building with uses of campus-wide importance.

1. Screen rooftop mechanical equipment and incorporate into building roof architecture. Roof volumes may contribute to accentuating primary building entries.
2. Provide large roof overhangs to cap building volume and contribute to sun shading.
3. Provide a ground level arcade on the Canyon Crest Mall facade, linked to buildings to the east.
4. Provide an articulated building base on all academic buildings facing primary public spaces.
5. To the extent possible, reserve ground level for public and active uses. Provide visual transparency into ground level interior spaces from adjacent public spaces.
6. Accentuate the building corner to enhance the connection between The Grove and Canyon Crest Mall.
7. Accentuate the primary entry and facade facing The Grove; the facade facing The Grove should incorporate a raised/articulated porch and continuous arcade or veranda form.

Figure 60 University Mall South

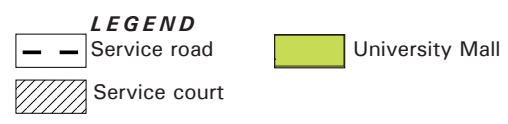





University Mall South

University Mall South lies at the southern extension of the University Mall as it approaches The Grove. Some buildings in this district front the continuation of the University Mall and should support its axial nature and high pedestrian activity level. Other buildings lie to the rear of the district, near the freeway and therefore have less prominence for the pedestrian, but high visibility for passing motorists.

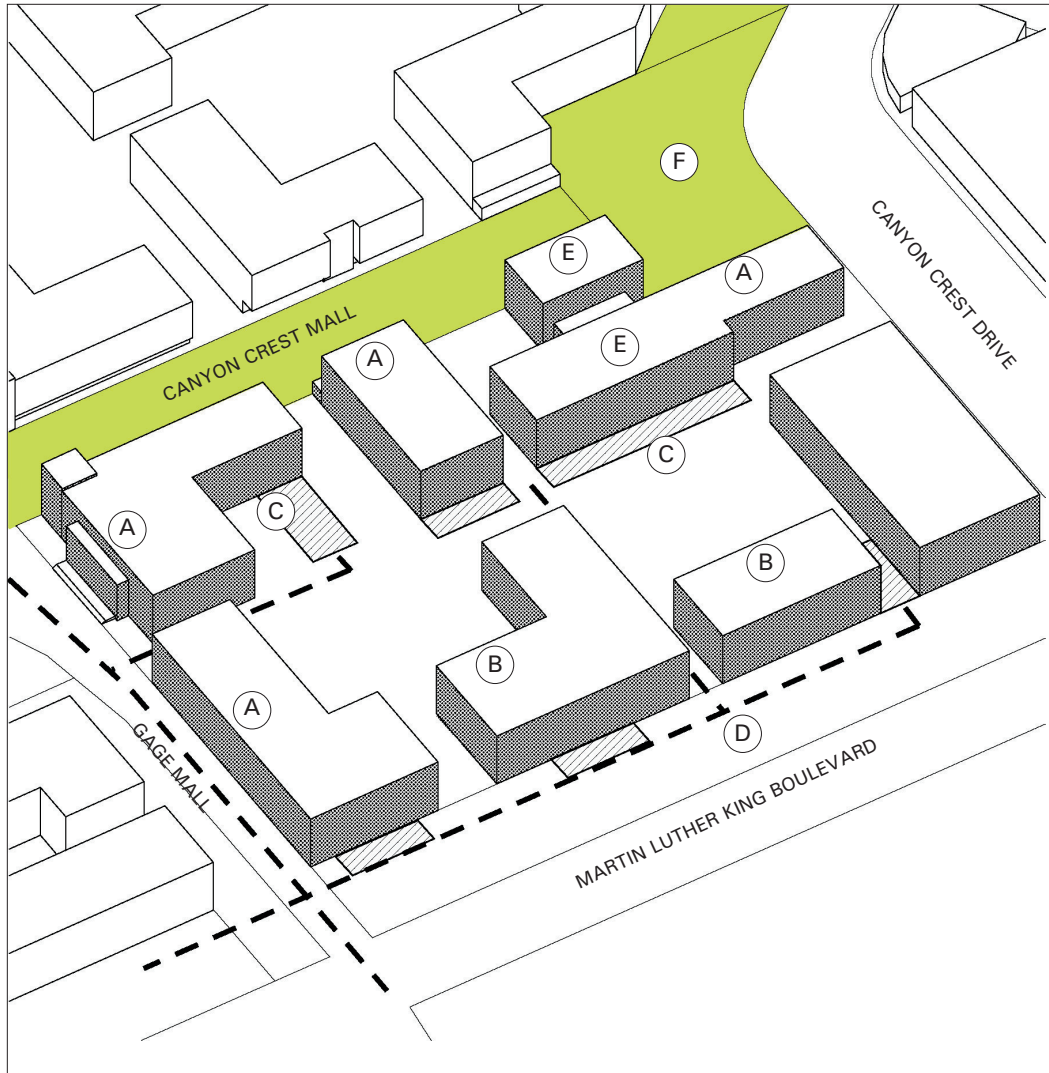
- A. Primary entries of buildings on University Mall should lie on this corridor. A continuous arcade should be provided for shade on all University Mall facades.
- B. Interior courtyards should be provided within the district, with shaded, landscaped, usable outdoor space.
- C. Buildings along the freeway can help screen noise from interior courtyards and pedestrian malls, and provide visibility for the University.
- D. Service routes should generally avoid high activity pedestrian corridors. Service areas for multiple buildings should be combined where possible.
- E. Convenient pedestrian connections will be provided from building courtyards to the primary open space network of Malls and The Grove.
- F. University Mall Buildings - These buildings should create a unified and well defined campus space that connects the campus entry at University Avenue to The Grove. The buildings at The Grove should also mark the prominent intersection of University Mall and The Grove with a taller element or other articulation. Buildings along University Mall should also provide a continuous arcade/covered walk along the University Mall linking University Plaza and The Grove.

Figure 61 Southeast District



- LEGEND
-  Service road
 -  Service court
 -  Canyon Crest Mall

Southeast District

The Southeast District lies immediately adjacent to the major campus vehicular entry at the intersection of Martin Luther King Boulevard and Canyon Crest Drive; as a consequence, this district will contribute importantly to the overall image of the campus. The Professional and Graduate School Center is planned for a site on Canyon Crest Mall in this district. That building will provide an important visual orientation and landmark at the entry to the academic core from the Canyon Crest under-crossing. Other professional schools are likely occupants of this area.

- A. Primary building entries should address Canyon Crest Mall, Canyon Crest Drive, or Gage Mall. These locations provide good visibility and identity for the public who may approach via Martin Luther King Boulevard and/or Canyon Crest Drive.
- B. Other building entries should occur from interior courtyards.
- C. Building service areas should be screened from public view.
- D. Service access is provided from Gage Mall and intersecting routes aligned to avoid heavy pedestrian and bicycle traffic areas.
- E. The initial building site in this zone, the Professional and Graduate School Center, should lie immediately adjacent to Canyon Crest Mall, visible from the East Campus and the Canyon Crest under-crossing. This building should include a visually prominent landmark element on axis from East Campus that can act as a beacon and orienting device.
- F. The intersection of Canyon Crest Mall and the Canyon Crest under-crossing - Canyon Crest Plaza - is a particularly important entry into West Campus.

Figure 62 Southwest District

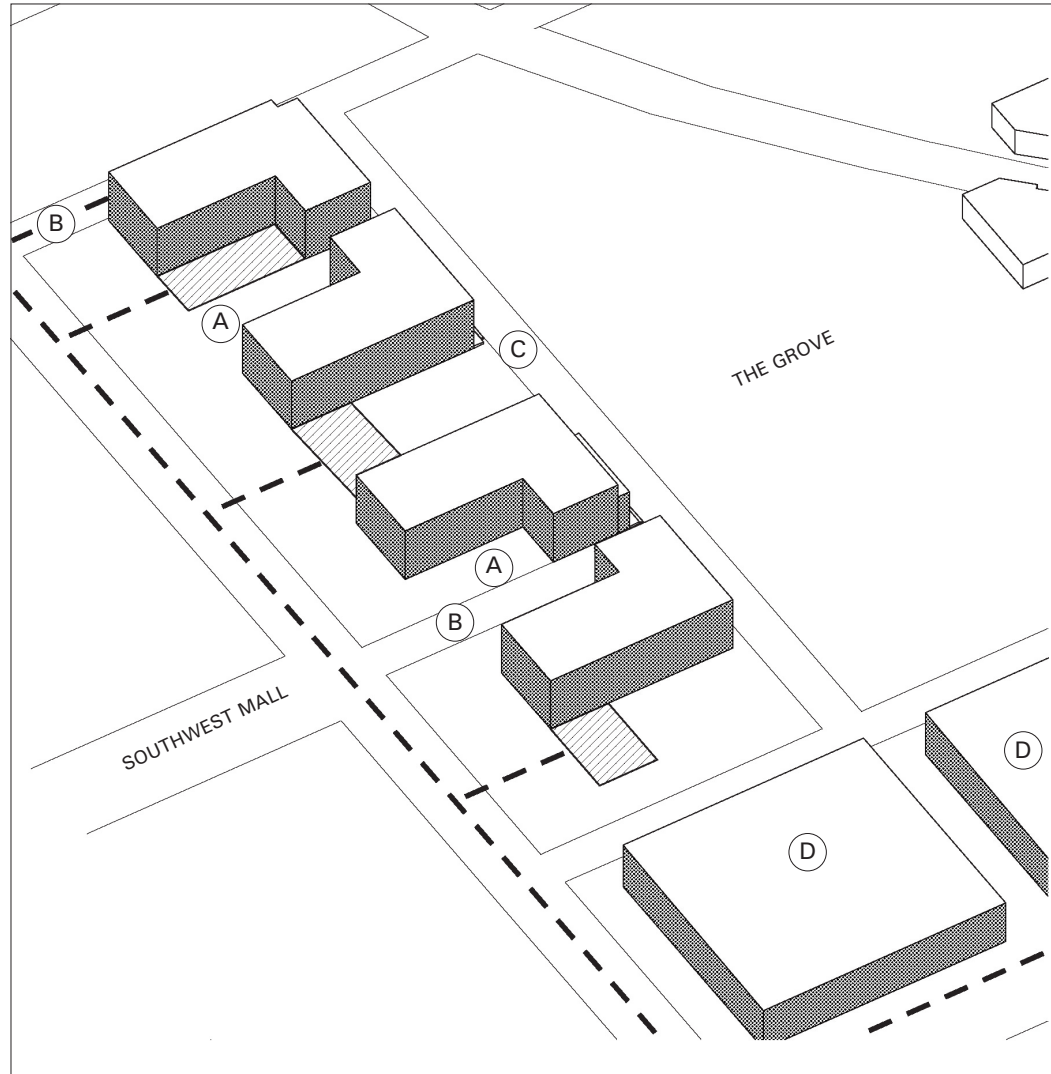

Southwest District

The Southwest District lies west of The Grove, adjacent to the future student apartment area. Buildings in this district will front on The Grove, but must also facilitate connections west to the student housing areas. Buildings on the west side of The Grove must reinforce the edge of The Grove and the pedestrian walkways that constitute the Grove Frame.

- A. Buildings in this area should include shaded, protected courtyards that can provide secondary building entries and connections to the west housing areas. Northwest Mall and Southwest Mall, important pedestrian malls connecting through the housing neighborhoods and linking the academic core to the recreation facilities to the west,
- B. Northwest Mall and Southwest Mall, important pedestrian malls connecting through the housing neighborhoods and linking the academic core to the recreation facilities to the west must be clearly connected through to The Grove.
- C. Primary entries of buildings facing The Grove should be raised above prevailing grade, with an entry porch or a veranda across the facade.
- D. Southwest Parking Structures (see following page).

LEGEND
 - - - Service road
 [Hatched Box] Service court

Figure 63 South West Parking Structures

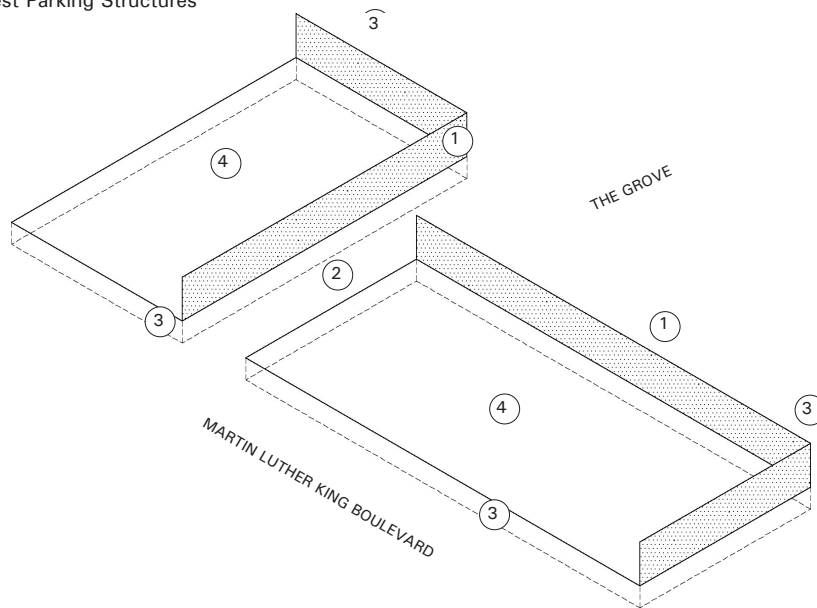

D. Southwest Parking Structures

These structures should be designed to maximize parking capacity and provide efficient ingress and egress, while appropriately framing The Grove and facing adjacent academic buildings.

1. Facades of the parking structures that face The Grove should include elements similar to academic buildings in other Grove-front locations. An articulated base, and clear building entries will help fit these buildings into the Grove Environment. All facades should screen parking while allowing light and ventilation. Facade lines should be orthogonal, with sloping floors and ramps contained within the structure.
2. Locate primary vehicular access points between the adjoining parking structures or along the Martin Luther King Boulevard facades. Limit vehicular access in areas adjacent to academic buildings.
3. Limit building height to 45' above grade or five stories or less. Provide below-grade parking as necessary.
4. Screen rooftop parking and mechanical equipment and incorporate into building architecture.

Residential Area Guidelines

The residential areas of the West Campus have been planned to create distinctive neighborhoods. Two general types of housing have been programmed for the West Campus: family housing for students with dependents; and apartment housing, oriented toward graduate students, and older undergraduates. This housing is of a configuration that would also be suitable for faculty and staff, if desired.

The layout of the residential areas is based on a traditional network of streets and blocks. Block sizes are approximately 300 feet square, typical of small town or urban neighborhood blocks. Streets are narrow and lined with trees, with building entries facing the sidewalks and parks. This will ensure a highly pedestrian-friendly neighborhood character, while contributing to neighborhood safety and security.

While local traffic for residents and visitors will be allowed, and on-street parking provided, through traffic will be discouraged by not connecting neighborhood streets to major roadways such as Chicago Avenue and Martin Luther King Boulevard. Access to the neighborhoods primarily will be via Iowa Avenue.

Iowa Avenue itself will be as narrow as feasible to make pedestrian crossing easy and safe, and to discourage speeding and unnecessarily high traffic volumes. It is planned to be one moving lane in each direction, with left turn pockets as needed at major intersections. Improvements to Iowa Avenue will also include sidewalk widenings at corners to facilitate pedestrian crossings.

Building Setbacks

Throughout the residential areas building setbacks are identified to fit the particular context - more generous setbacks along primary and secondary vehicular roadways, and minimum setbacks along local streets that emphasize pedestrian and bicycle access.

Along Martin Luther King Boulevard, a generous setback will be provided between the roadway and any residential units. The setback will include the landscaped drainage

swales of the site drainage system, as well as additional landscaped areas, and minor service routes.

Along Iowa Avenue and the two east/west malls - Northwest and Southwest Mall - setbacks will be in the range of 20 feet. Elsewhere setbacks will be minimal, up to 10 feet, where townhouses and apartments will face active sidewalks.

Figure 64 Residential Setbacks

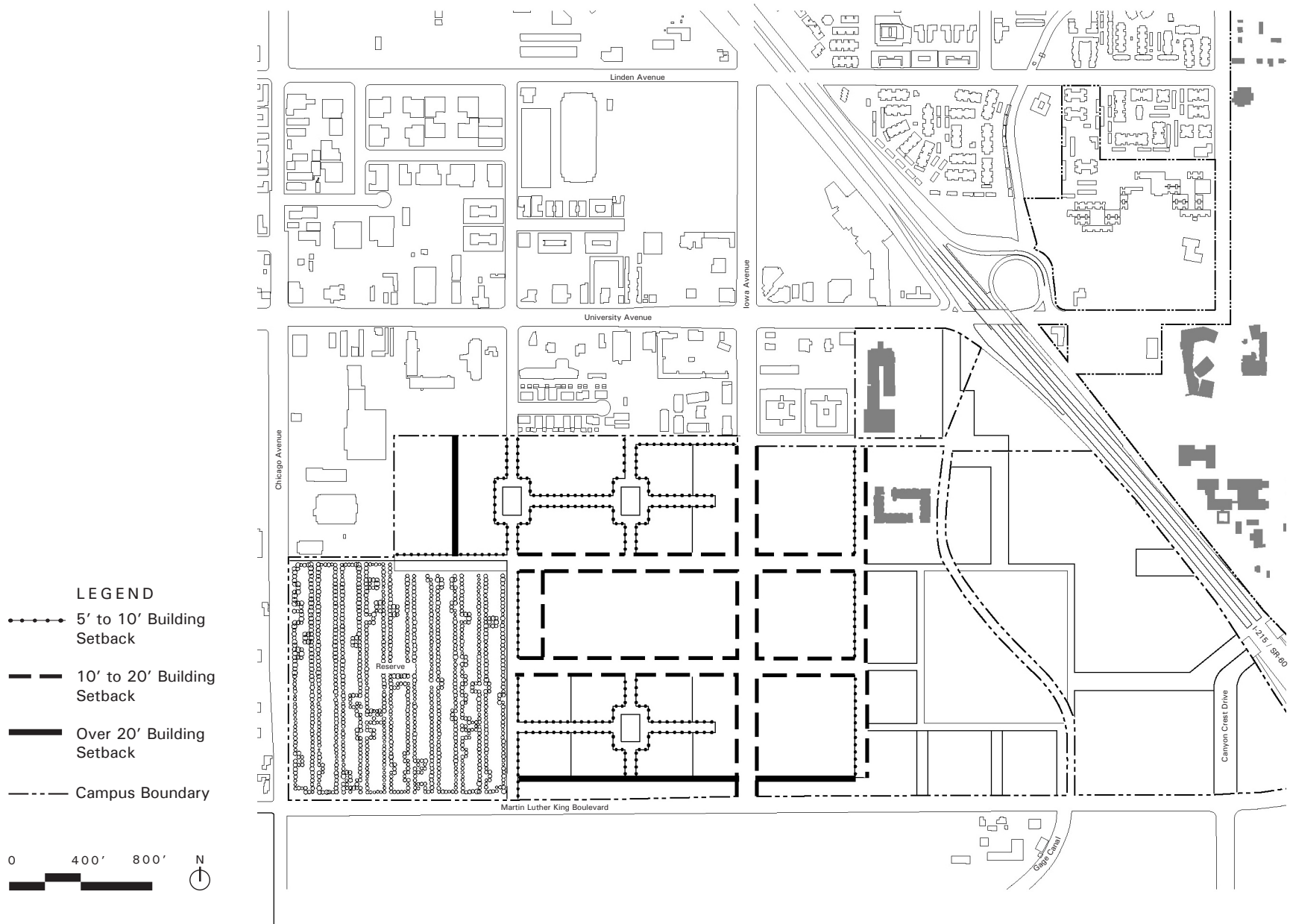

Family Housing Design Guidelines

The diagram at the right illustrates a possible layout of a family housing neighborhood block. It is intended to be a diagram for illustrative purposes only; ultimate design of these areas should, however, follow the general rules described below.

Block Layout

The family housing neighborhoods are focused around neighborhood parks. These parks are surrounded by narrow neighborhood streets, intended to be one way in order to minimize roadway width and facilitate pedestrian crossings, while avoiding privatization of the park space.

Unit Types and Layout

Family housing will include two unit types. The first, townhouses, may include two to three bedrooms, suitable for families. These units are shown surrounding the neighborhood parks, and could include small rear yards. Parking would be provided on site in a carport or garage, and/or on the street. Apartments or stacked full floor units (flats) are the second unit type. Clusters of these units would be planned to include shared tot lots or small play areas, suitable for the smallest children, located on site to avoid the need for crossing streets.

Building Entries

Buildings entries for all unit types should face the streets and neighborhood parks. Porches, verandas and balconies are encouraged overlooking the neighborhood streets.

Building Scale and Form

Family housing units can range from two to three stories. Shaped roofs, sun shading, and wide eaves are encouraged to moderate building bulk and contribute to a neighborhood character. Variations in the scale and mass of building elements, such as entries, should be used to reinforce a pedestrian scale along street facades.

Apartment Housing Design Guidelines

This section does not illustrate a typical apartment neighborhood, however the following general guidelines apply.

Densities

The apartment units will occupy a neighborhood separate from the family units and will accommodate graduate students and older undergraduates. These units are planned at higher densities than the family housing units.

Unit Types and Layout

The apartment units will likely include shared recreation facilities such as swimming pools, basketball courts, lawns and fitness rooms. Parking will be provided on site and on the street. Parking lots fronting on the streets should be limited.

Building Entries

Building and unit entries should front the streets rather than being internalized within the complex, to support neighborhood character and street activity. Porches, verandas and balconies are encouraged overlooking the streets.

Building Scale and Form

Apartments will range from three to four stories. Shaped roofs, sun shading, and wide eaves are encouraged to moderate building bulk and contribute to a neighborhood character. Variations in the scale and mass of building elements, such as entries, should be used to reinforce a pedestrian scale along street facades.

Child Care Facility Design Guidelines

Programmatic and site requirements of the childcare facility are described earlier in the Facilities Program section of this report. Two of these facilities are planned to be located in the family housing neighborhoods of the West Campus.

Each childcare facility should be designed to fit in well with the residential neighborhood in which it is located. They should comply with the design guidelines for family housing as appropriate for a facility that will need to ensure the safety of up to 150 small children. Building massing, scale and character should be similar to the family housing units.

Figure 65 Illustrative Family Housing Neighborhood Block

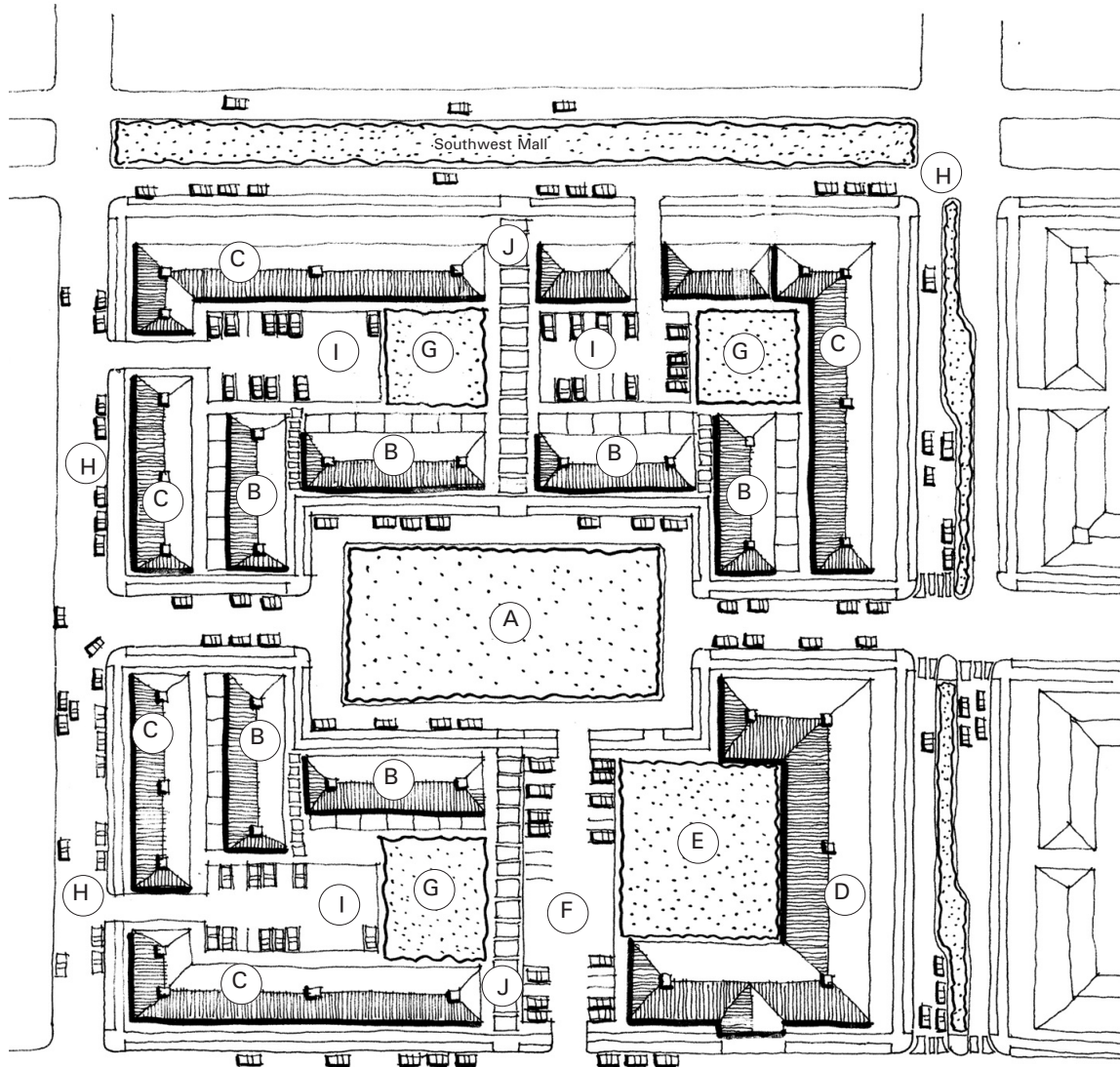

- A. Neighborhood park surrounded by one way local street
- B. Townhouses surrounding neighborhood park
- C. Stacked flats facing peripheral streets
- D. Child care center
- E. Child care dedicated open space
- F. Parking for child care center
- G. Tot lot
- H. On-street parking on all surrounding streets except lowa.
- I. Additional on-site parking as required. Does not face street
- J. 40' wide (facade to facade) mid-block pedestrian connector

Landscape Guidelines

Landscape Improvement Goals

Goals of the landscape framework for the West Campus include:

- Reinforce and express the natural systems of the campus where they remain
- Provide a unique and attractive image of the campus, which derives from the citrus heritage of the region, UCR as a whole, and the previous uses of West Campus agricultural research lands.
- Develop a landscape that achieves the above while maintaining water conservation and water efficiency practices
- Implement major elements of the landscape as early as possible to allow trees and other natural features to mature.

General Principles of Landscape Design

There are eight primary principles that guide the design of the landscape of the West Campus. These principles will guide the improvement of all open spaces and unbuilt areas of the West Campus.

Regional Expression

The overarching principle of landscape design for the West Campus is to create a campus that is expressive and responsive to the history, character, climate and environment of the semi-arid desert region where the campus is located. This will distinguish the West Campus landscape from the East Campus landscape in several ways. The East Campus landscape until recently has been designed and developed on the model of the traditional American campus (invented in the eastern United States where natural rainfall is abundant) of large malls covered with lawns and shade trees.

The East Campus landscape thus bears little resemblance to either the natural or man-made environment of the Riverside/San Bernardino County region. Several factors distinguish this region from the type of environment of the traditional American campus model:

- The dominant man-made expression of landscape in the region has been that of citrus agriculture.

- The non-agricultural landscape was devoted to unique definition of roads and boundaries.
- Where intensive gardens are found, they are located in courtyards protected and defined by buildings.

The dominant natural expression - which continues to be a primary component of the landscape today - is the semi-arid desert with rocky hillsides and arroyos filled with willow, cottonwood, elderberry, mulefat, and walnut.

These pervasive elements of regional landscape expression have not been well understood or served as a basis for urban and campus development in the past. However, they can be the basis of sustainable campus development in the future and will establish the vocabulary and image of the West Campus. More than any other factor, this regional approach to landscape expression will make UCR unique among university campuses.

Citrus Heritage

The landscape framework of the West Campus will be derived from a symbolic expression of the citrus heritage of the region, the City and the University. The Grove, the Malls, building courtyards and spaces, and even buffer landscapes separating incompatible land uses (such as the freeway) are intended to be improved and developed with patterns, materials and scale derivative of this landscape heritage.

Roads/Boundaries/Connections

An element of the citrus heritage of the region is the landscape expression of roads, boundaries and connectors. Reminders of these linear elements remain visible in the rows of Palm and Eucalyptus that can be seen around the region, the City and the campus. They are remnants of the citrus/agricultural landscape that once dominated the region, defining the boundaries of properties, roadways, entrance drives, and sub-areas of the landscape, thereby assisting in wayfinding and providing focal points and definition in an otherwise undifferentiated agricultural and urban landscape. It is intended that the malls and linear open spaces of the West Campus be designed as a contemporary expression of this linear landscape demarcation.

Arroyos

Drainage is an essential component of any environment. In the natural environment of Southern California drainage takes the form of arroyos that are generally wet and flowing during storm events and dry during the many dry months of the year. In addition to providing for surface run-off, natural ponding occurs which slows velocities and provides detention to allow percolation, infiltration and aquifer recharge.

The natural arroyos are also quite attractive. Granite boulders, sandy bottoms lined with vegetation such as willow, cottonwood and mulefat give definition and seasonal color to the landscape, and segment the larger landscape into identifiable units, similar to the way roads and boundaries, and connectors segment man-made citrus agricultural landscape.

Wherever possible, it is the intention to develop a new system of arroyo drainage to provide surface runoff and detention for major storm events in an attractively natural way. These arroyos will be located in the Northwest Mall, the Southwest Mall and within the buffer zone separating the West Campus from Martin Luther King Boulevard.

Sustainability

Like building development, all site improvements throughout the West Campus should seek to maximize long term sustainability. This includes:

- Use of Best Management Practices for drainage design
- LEED certification or similar standards for new development, including attention to site improvements
- Drought tolerant plantings (xeriscape)

Turf areas will be limited to specific focused areas where their use is functionally necessary (recreation fields, courtyards for study, and specific ornamental areas). Development of high water consumption, high intensity gardens will occur only in focused and specifically targeted areas.

Courtyards and Gardens

Throughout the desert regions of the world there has

been a natural tendency among settled societies to create protected, cool, moist garden living environments. Indeed, in some desert cultures heaven is envisioned as a garden, generally surrounded by a protecting wall separating it from the surrounding harsh environment. This is also true in the historical heritage of the southwest region, where courtyard gardens were an integral part of the Mission architectural heritage. The Mission Inn in downtown Riverside is a good example of this focused landscape expression.

In many ways the East Campus is a large expression of this landscape contrast with the surrounding natural environment. However, as mentioned previously, the focused approach has not been followed systematically in the East Campus, which is consequently not truly in character with either the man-made heritage of landscape or the principles of sustainable site development that would be appropriate to the Riverside region.

The shaded, cool, moist landscape will be an important component of the West Campus. However, it is intended that it be developed in a focused manner in protected courtyards. This image is derivative of two aspects of regional heritage: the courts created by the grouping of domestic and functional buildings in a citrus agricultural setting, and the Mission Revival architecture that became, for a time, indigenous of the region. Such places will be found throughout the campus, generally associated with specific building development and complexes. The landscape character of these focused, protected areas may take a variety of forms, ranging from lawns to small citrus groves to tropical shade gardens. The most important principle is that they be specific, localized, and focused in their use of resources. Outside these water-intensive zones, a landscape of low water use (xeriscape) will form the fabric of the West Campus.

Safety and Security

The assurance of safety and security is critically important in all areas of the campus. Throughout the West Campus site planning and building and landscape design will pay particular consideration to these concerns. Unique considerations will pertain in areas such as The Grove (visibility), Iowa Street (safe street crossings), and University Mall at the I-215/SR-60 interchange (modify to

improve crossing safety). In general, improvements will be based on the following principles:

- Streets and circulation routes will be designed to maximize pedestrian priority and safety
- Landscape improvements will be maintained to provide maximum visibility and avoid large isolated areas.
- Adequate levels of pedestrian lighting will be provided in all malls and public open spaces.

Landscape Framework Plan

The Landscape Framework Plan on the right illustrates the primary components of the landscape of the West Campus. Landscape plantings will be applied to the open spaces of the campus as well as to streets and other components such as buffer. The sections that follow illustrate the design guidelines for all of the Landscape Framework elements.

Figure 66 Landscape Framework

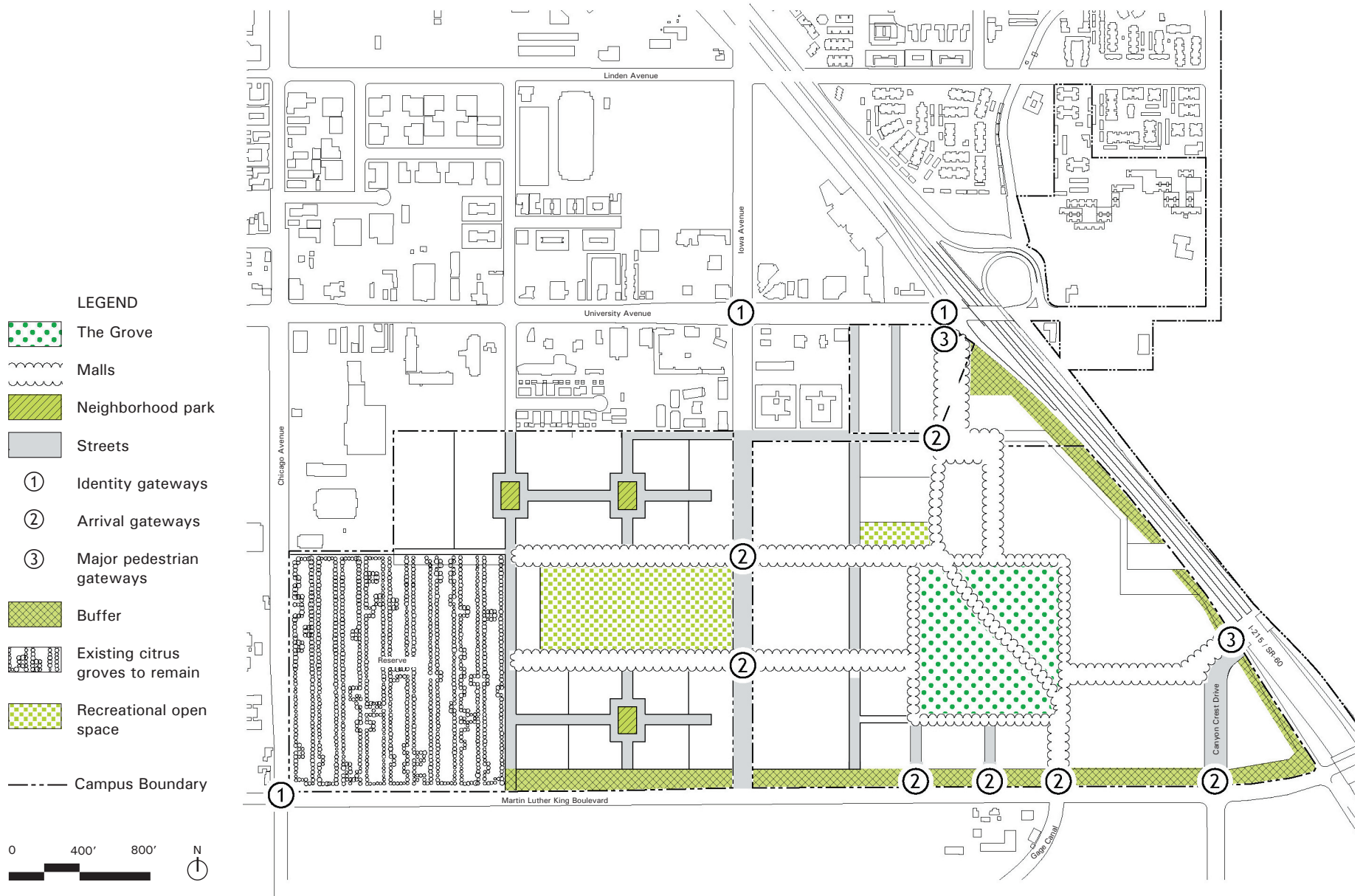

The Grove

The Grove is intended to emulate a typical block of citrus tree plantings. It is large enough to constitute a major open space within the West Campus, establish a lasting legacy of the University citrus/agricultural heritage, and provide opportunities for creation of different citrus “blocks” similar to those found in commercial agriculture and existing University research groves. The Grove is approximately 800 by 850 feet, about three city blocks long on a side. It will generally comprise plantings of a variety of citrus species, arranged in blocks representative of the research blocks of the West Campus today, and of the variations in citrus agricultural plantings. Blocks will be approximately 100 feet square, allowing a row spacing of about 25 feet and tree spacing of approximately 15 feet similar to typical citrus groves. This will result in about 25 - 30 trees per block.

While the plantings within blocks may vary, it is generally intended that they represent citrus species. However, it is not intended that The Grove be devoted exclusively to citrus. Other uses may be introduced into The Grove. Due to the symbolic importance of The Grove, however, only uses that are of campus-wide importance, or are particularly symbolic to the University, should be introduced here. This might include a West Campus student common, campanile as described in the previous section, public art, and areas for public gathering such as an amphitheater.

Care must be taken not to overly fill The Grove with uses. Over time it will become a cherished place of the Riverside campus and must be devoted primarily to expression of the citrus heritage landscape.

Buildings that are introduced into The Grove have special responsibilities. They must be responsive and derivative (yet contemporary) to the site planning and design characteristics that comprise the traditional agricultural landscape (see Architectural Design Guidelines).

Within The Grove, the 100-foot square citrus blocks will be framed by a grid of pedestrian walkways. These walkways will be surfaced in hard or soft materials, depending on the projected intensity of pedestrian use, and in order to optimize maintenance.

While it is the intent to replicate the symbolism of the citrus heritage as closely as possible, practical considerations require that The Grove be maintained with particular features that may vary from a strictly agricultural application since it must function in a pedestrian-dominated campus setting. Among specific design issues to be addressed are:

- Security: Citrus trees typically have low branching (or “skirts”) nearly to the ground. In The Grove these lower branches will be pruned up to allow visibility for safety and security.
- Tree protection: Free movement in and among the individual citrus trees will be discouraged (though not entirely limited). To achieve this the individual blocks will be raised 6 to 12 inches above the grid of walkways, or other simple, small-scale separations will be created.

Figure 67 The Grove

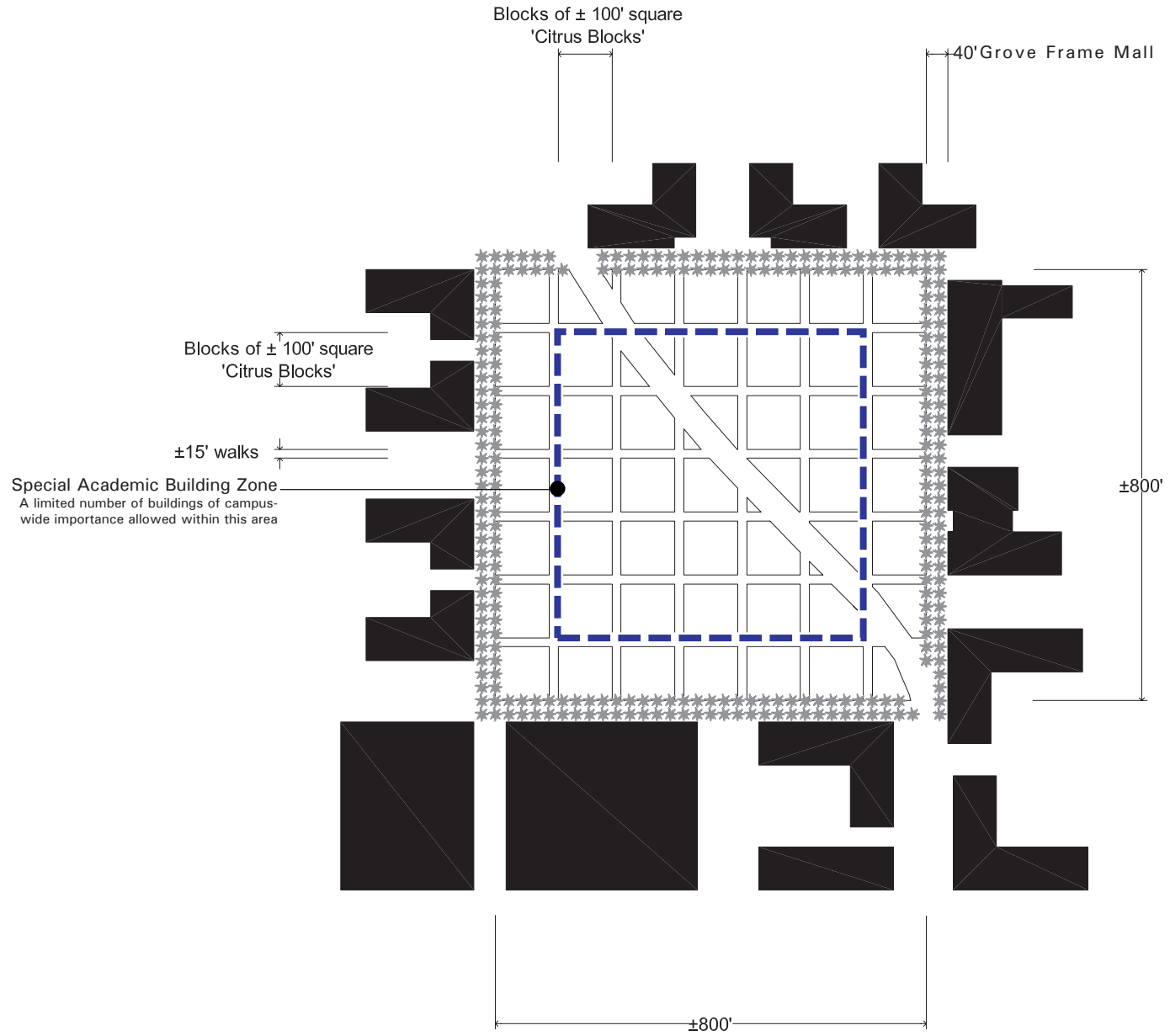

West Campus Malls

The malls and linear open spaces of the West Campus are intended to give legibility and structure to the campus and provide direct attractive connections to the heart of the academic campus through an attractive, shaded landscape. There are six major malls and linear open spaces:

- The Grove Frame
- University Mall
- Canyon Crest Mall
- Northwest Mall
- Southwest Mall
- Gage Mall

The landscape of all of these spaces will share several common features including:

- Rows of tall trees such as palms, eucalyptus, or poplar expressive of the rows of tall trees found in the citrus/agricultural landscape
- Rows of shade trees such as California Pepper, Horsechestnut, and Oak (perhaps alternating with the taller trees) to provide shade for pedestrians and bicyclists.
- Low water demand shrub and ground cover plantings (xeriscape)
- Consistent pedestrian scaled lighting that defines this system of open space at night.

The historic Victoria Avenue in Riverside is a classic example of this treatment, providing multiple benefits including an alternative shaded street environment and definition of the larger agricultural landscape.

While the design of all of the malls and linear open spaces is generally intended to be similar and consistent, each will have specific unique characteristics as well. In particular the Northwest Mall and the Southwest Mall will include:

- Local access streets (one lane in each direction with parking)
- Surface water drainage carefully designed as a natural arroyo with integrated detention ponds.

The following pages provide a more complete description of the landscape improvements intended for the major malls and linear open spaces. The key plans identify illustrative locations of the cross sections diagrams that accompany the descriptions.

Figure 68 West Campus Malls and Neighborhood Park Key

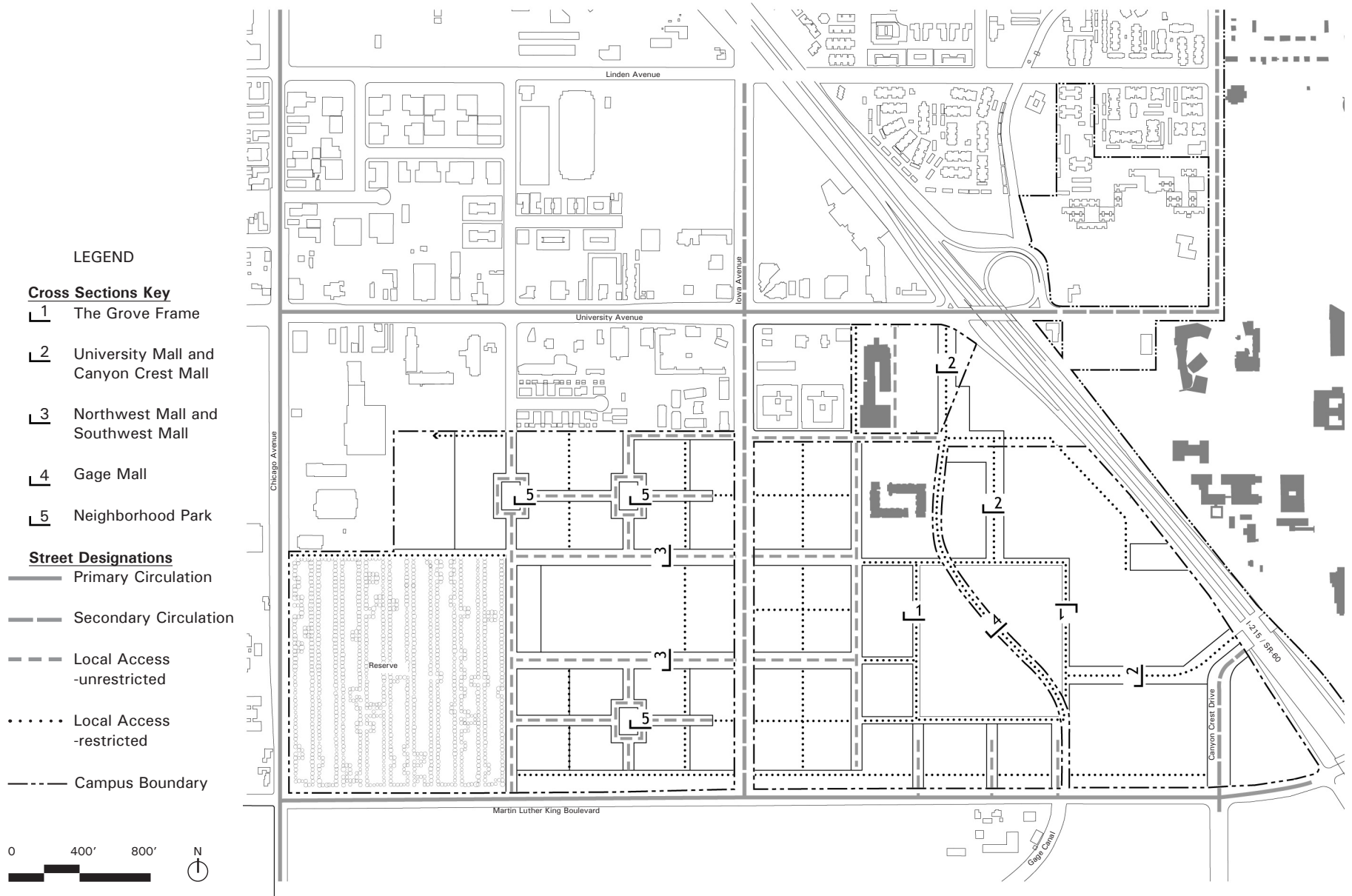

The Grove Frame L1

As a focal point of activity within the West Campus The Grove will be both an important destination and an important path of the campus community. In order to accommodate high levels of pedestrian movement and define an organized setting for the siting and access to academic buildings, the Grove will be surrounded on all four sides by a 40-foot wide mall known as the Grove Frame. The Grove Frame will provide clear definition of the edge of The Grove through both landscape improvements and buildings. The Grove Frame is derived from an expression of the public roadways found in the traditional citrus agricultural landscape. Alternating palm trees and shade trees provide definition and visibility of The Grove as well as a comfortable environment for pedestrians. Within the landscape setting of The Grove Frame a continuous paved pedestrian and bicycle path with a minimum width of 20 feet (suitable for emergency access) will be provided.

Buildings lining the Grove Frame have special responsibilities. They will be designed to include porches and verandas overlooking The Grove and the Grove Frame much the way buildings face the road and overlook the groves in a citrus/agricultural setting (see Building Design Guidelines).

University Mall and Canyon Crest Mall L2

These two malls are particularly important as they provide direct linkages between the academic core of the West Campus and the academic core of the East Campus. Therefore it is crucial that the landscape of these malls be clearly defined. Generally landscape improvements will be similar to those found in the other malls and linear open spaces. Alternating tall trees such as palms and shade trees will clearly define the linkage from the East Campus when viewed from afar and contribute to the definition of the quadrants of the overall campus. Xeriscape plantings will be the dominant plantings on the ground plane. Due to the width of these spaces there is also the opportunity to establish a pattern of landscape “blocks”. These blocks may be planted in smaller “mini groves” of citrus or other non-citrus, ornamental species such as Crape Myrtle, or lawn panels in specific locations. It is not however intended that these malls become continuously planted in lawns as found in the East Campus.

Figure 69 Grove Frame L1

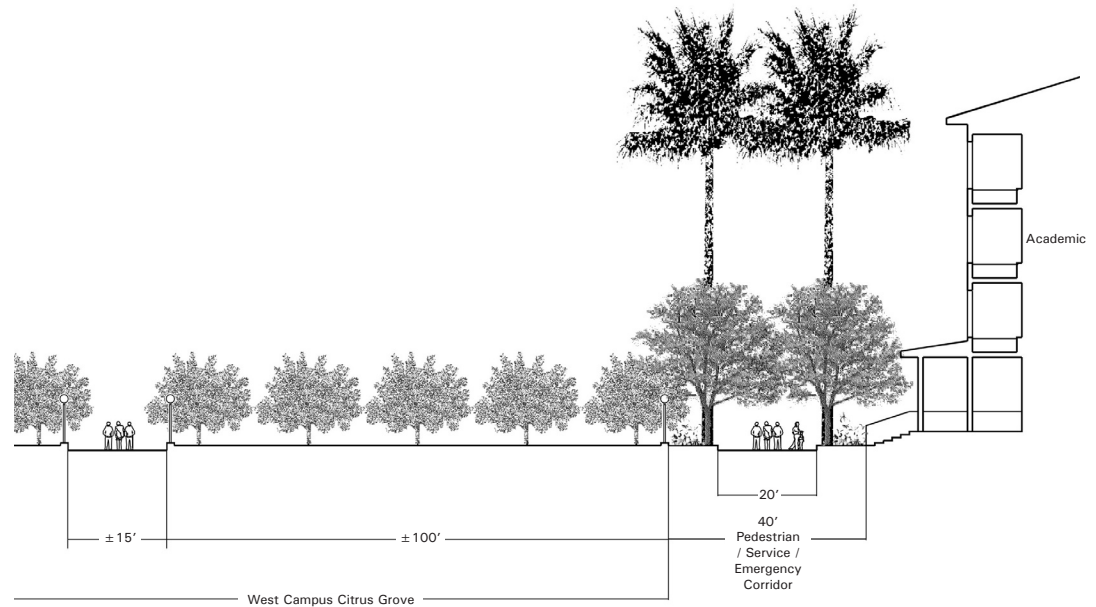

Figure 70 University Mall/ Canyon Crest Mall L2

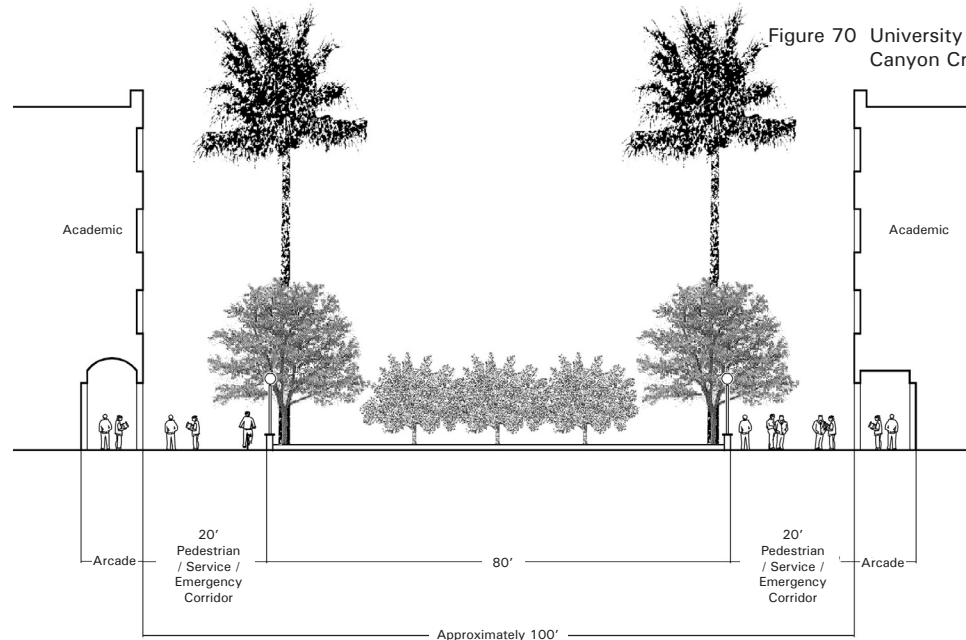

Figure 71 Northwest Mall / Southwest Mall L3

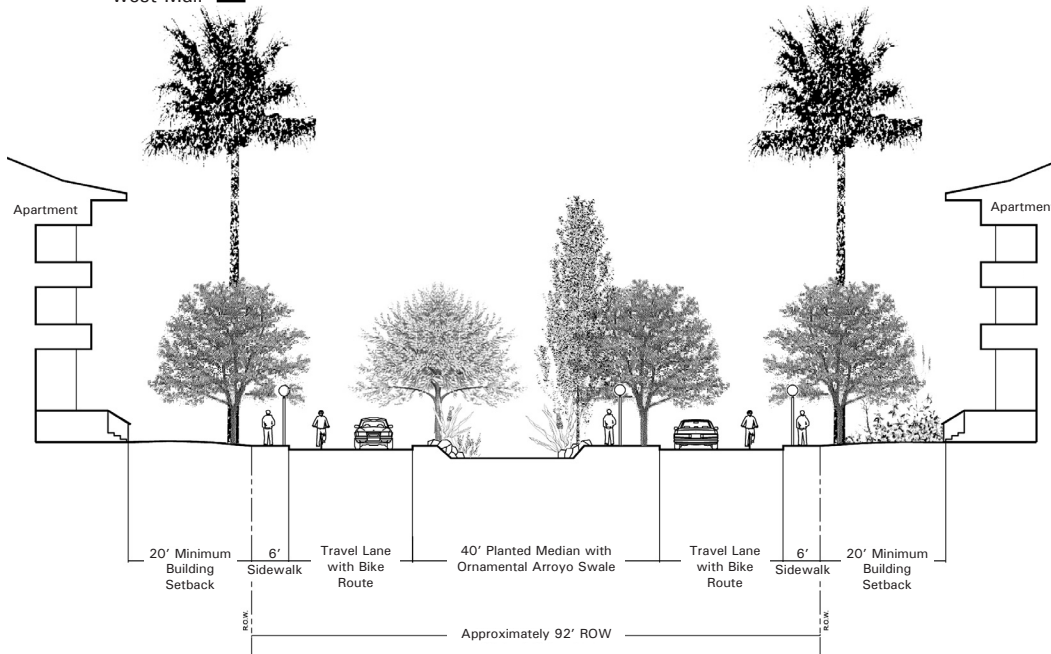
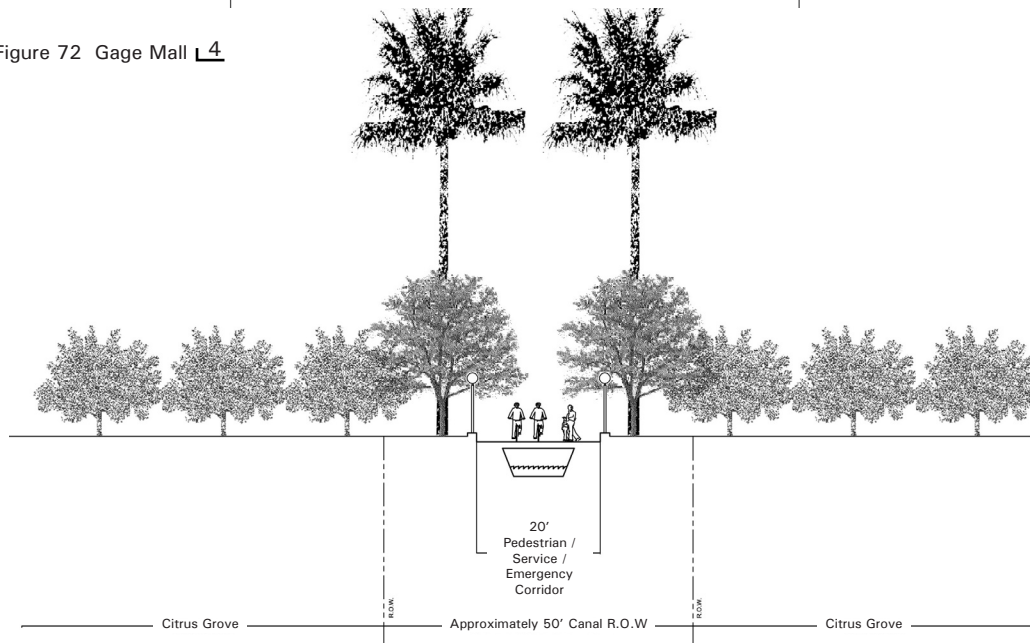

Figure 72 Gage Mall L4



Northwest Mall and Southwest Mall L3

These two malls provide important pedestrian and bicycle connections from the residential and recreational areas at the far west reaches of the West Campus to the academic core and the East Campus beyond. Unlike the other malls of the West Campus they will also accommodate general local vehicular access. In terms of width and scale, these malls are similar to one of the most distinctive streets on the East Campus, Aberdeen Drive. With its very wide planted median and wide planted setbacks, it is a beautiful connection for pedestrians and bicyclists.

The landscape treatment of Northwest Mall and Southwest Mall will be different from Aberdeen Drive in noticeable respects. Like the five other major malls and linear open spaces on the West Campus they will be designed with tall structural planting expressive of the roadways in citrus agricultural areas. In addition, these two malls will be an important part of the surface drainage concept for the West Campus (see also Infrastructure section of this report). This surface drainage will be designed to replicate the natural arroyos and basins of the region. Naturalistic plantings typical of an arroyo will supplement the strong lines of alternating palms and shade trees.

Gage Mall L4

In cooperation with the Gage Canal Irrigation District, UCR is planning to pipe and cover the Gage Canal as it passes through the West Campus in order to protect irrigation water quality, assure safety, and to minimize maintenance concerns. When covered it will be suitable for pedestrian and bicycle access, as well as limited service and emergency vehicle access. Since the Gage Canal corridor links the majority of the academic core of the West Campus with University Avenue on the north, and Martin Luther King Boulevard on the south, it is a key corridor and should receive priority treatment for comfort and as a visual amenity.

While the canal covering cannot be planted, the corridor will be planted outside of the setback zone. In this area it is envisioned that tall linear planting and shade trees will provide a visual orientation to the heart of The Grove and the academic core, passing through the key site of the Inner Grove Buildings (see Building Design Guidelines). Plantings

will also provide shade for pedestrians and bicyclists. The curvilinear line created by the tall landscape following the Gage Mall will establish a strong counterpoint to the orthogonal grid of The Grove and the West Campus.

Neighborhood Parks L5

As shown in the Land Use Plan and Open Space Plan, neighborhood parks are planned in the Family Housing area in the west portion of the West Campus. These parks will serve as local open space for families and the larger campus population. Since children will be living in these areas and using these parks, they will be improved as simple turf areas for active play. The street surrounding the parks will be surrounded by a double row of shade trees of similar species to those used on local access streets around the area. Also surrounding the open turf areas beneath the shade trees will be benches, pedestrian scaled lighting and other street furnishings.

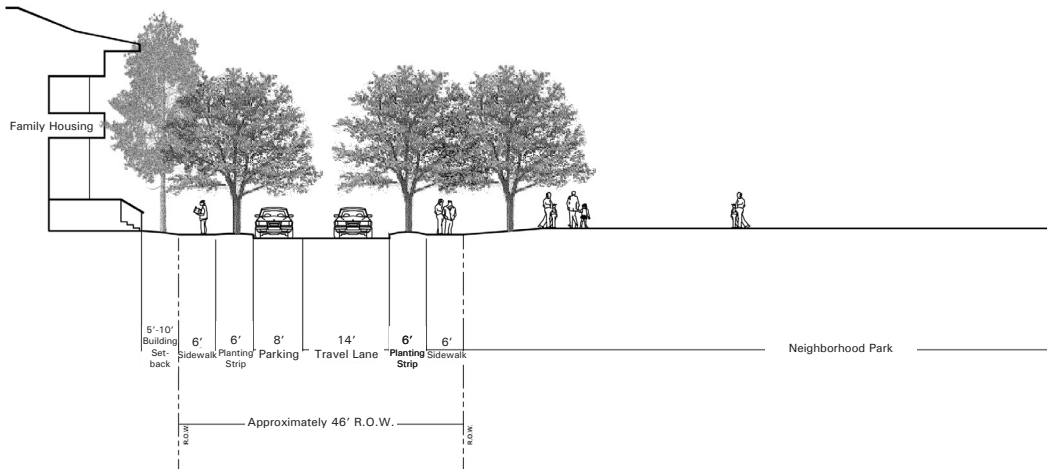

Streetscape

The streets of the West Campus are intended to provide attractive access to the gateways and high image areas of the academic core such as professional schools and the conference center. Further west, they are intended to express a “Townscape” character typical of small town residential areas and promote establishment of a neighborhood setting through their layout, scale, building orientation, and landscape improvements. This section describes the intended design character, with a particular emphasis on streetscape improvements, for the various vehicular streets of the West Campus. See also the Circulation section of this report for a discussion of the functional classifications and operational characteristics of West Campus streets.

From a street environment point of view there are six street types that will be found throughout the West Campus. These include:

- Martin Luther King Boulevard
- University Avenue
- Iowa Avenue
- Local access streets
- Pedestrian connectors
- Service roads

Figure 74 Streetscape, Gateways and Buffer Key

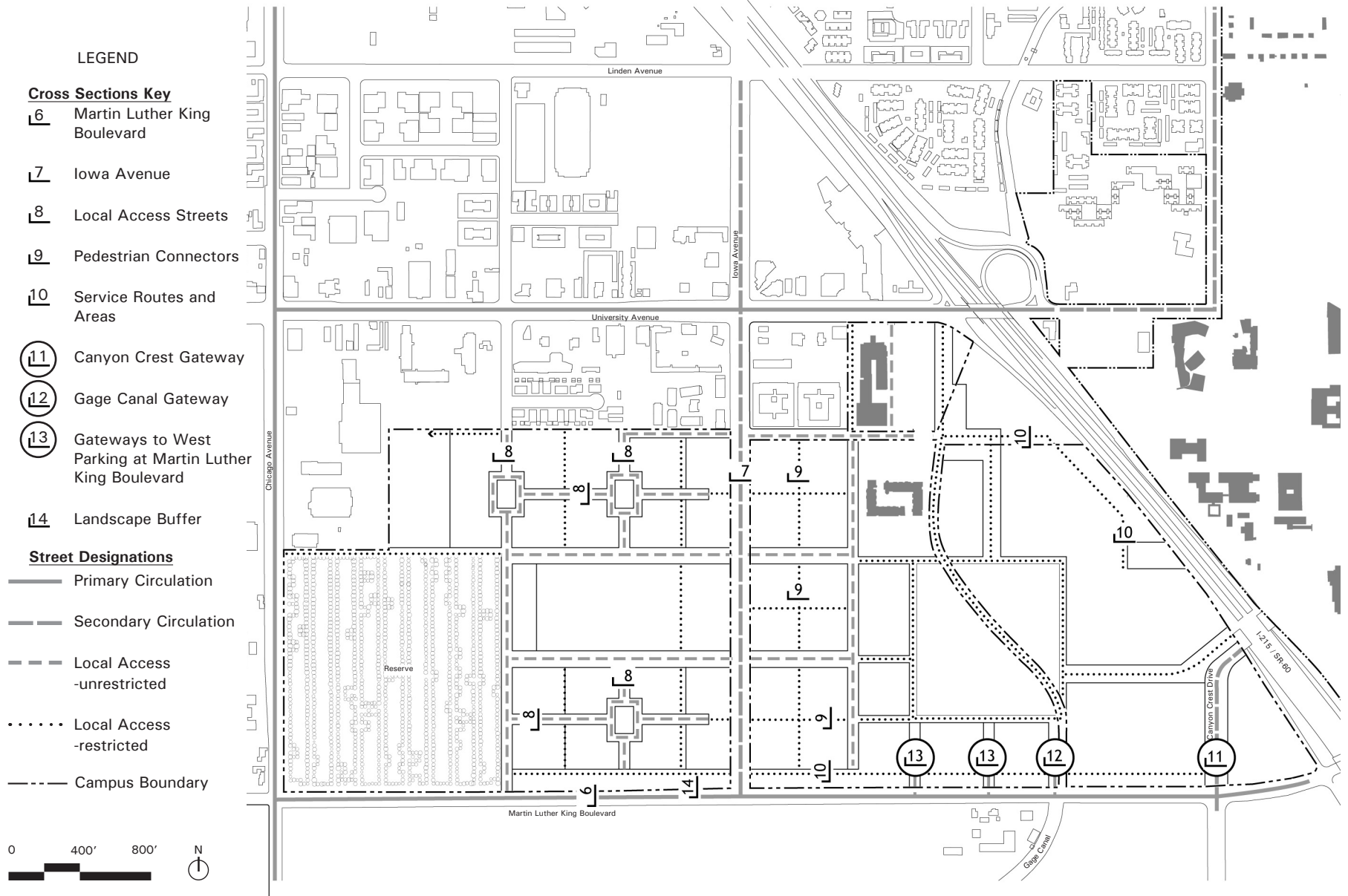

Martin Luther King Boulevard 6

Martin Luther King Boulevard will continue to function in its role as a major vehicular corridor for the City of Riverside and the campus, and serves as a major entry into the West Campus. When the I-215/SR-60 freeway widening and interchange improvements are completed in the next few years, this road will increase in importance as a regional linkage.

The general approach to streetscape along Martin Luther King Boulevard will remain relatively unchanged, with a planted central median and plantings on either side. However, it is intended that the corridor receive improved continuous sidewalks and significant additional street tree and median planting. As a street that will carry many visitors to the region and campus, Martin Luther King Boulevard should have a high level of landscape treatment characteristic of other important campus streets.

To the south of Martin Luther King, agricultural fields and orchards will remain for research. Immediately to the north of Martin Luther King, a linear swale/detention basin will be located within a 60 - 100 foot wide buffer zone. The improvements planned for this buffer zone are discussed in greater detail later in this section of the report.

Figure 75 Martin Luther King Boulevard 6

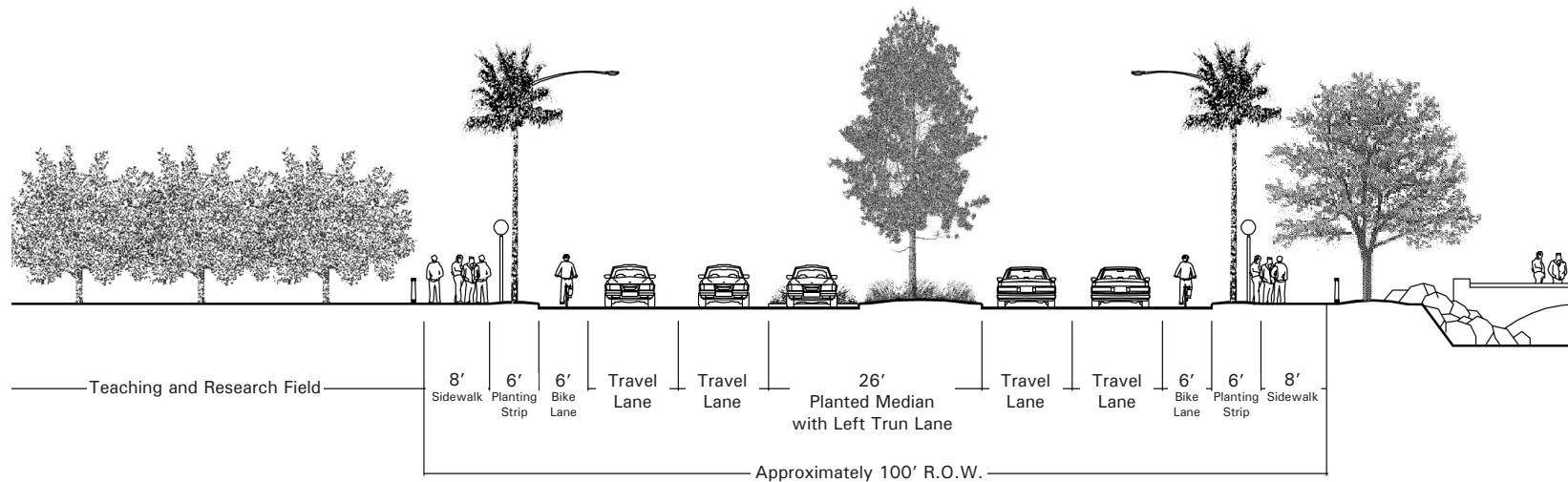

Iowa Avenue ¹⁷

The treatment of Iowa Avenue as it passes through the West Campus is of great importance to UCR since it bisects future residential areas of the West Campus. It will be particularly important that through traffic be minimized in order to ensure a quiet and safe street that does not become a barrier to pedestrian movement in the east-west direction. In addition Iowa Avenue must provide good access for the West Campus.

As shown in the cross-section, Iowa is planned to minimize the dominance of the roadway through abundant landscape improvements, short pedestrian crossing distances and refuges. It will contain one through lane in each direction, a large planted median with left turn pockets, Class II bike lanes, and sidewalks shaded by regularly-spaced street trees planted in a curbside planting strip. Traffic calming devices will be incorporated into the final design of the street wherever possible. These may include corner extensions, regularly-spaced traffic controls such as stop signs and traffic signals, pre-warnings staggerings, deflections, roundabouts, gateways and other measures.

A 20-foot landscaped setback from the property line (back of sidewalk) will be required for new buildings along this corridor to ensure an attractive campus appearance and to further buffer traffic impacts.

Iowa is not intended to convey an image as a major framework element of the West Campus. This is reserved for the major malls that lead to and surround The Grove and the academic core. Therefore tall plantings of palms, Eucalyptus or other citrus-heritage roadway expression are not appropriate for Iowa Avenue because such a treatment will interfere with the legibility of the overall West Campus landscape framework.

Landscape improvements to Iowa will be of a “townscape” character similar to the treatment of University Avenue. This will include: street trees for shade on both sides, a planted median that may contain citrus or ornamental trees in miniature geometric “grove-like” patterns. The ground plane landscape improvements will include xeriscape plantings of shrubs, groundcovers and ornamental grasses within the median, the side right of way and in the front yards (setback area) of the adjacent housing on both sides of the street. Continuous lawns are not appropriate or compatible with the landscape design concept for the West Campus.

Figure 76 Iowa Avenue ¹⁷

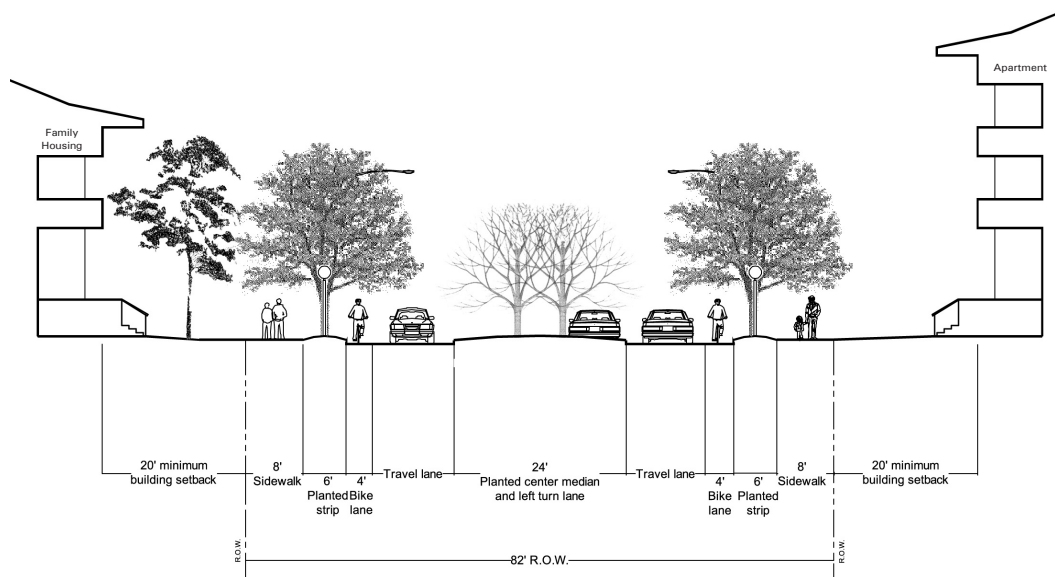

Local Access Streets ¹⁸

Local access streets provide connections and general traffic access throughout the West Campus to residential areas and to the edge of the academic core. These streets are not linked to the major vehicular corridors – University Avenue, Chicago Avenue, or Martin Luther King Boulevard - and therefore will not be through routes with high traffic volumes. The layout of local access streets is generally discontinuous in most areas to further discourage through traffic. (See also Circulation section of this report).

Local access streets will be narrow in cross section, with relatively narrow travel lanes to discourage speeding, and with parking on either side. There will be no striped bicycle lanes on these streets. These streets will be heavily planted with street trees in a landscape strip in order to provide a shaded canopy for pedestrians, bicyclists, and parked cars. Like most streets and open spaces on the campus, front yard building setback areas will be planted with drought-tolerant ornamental plantings (xeriscape). Lawn areas will be kept to a minimum.

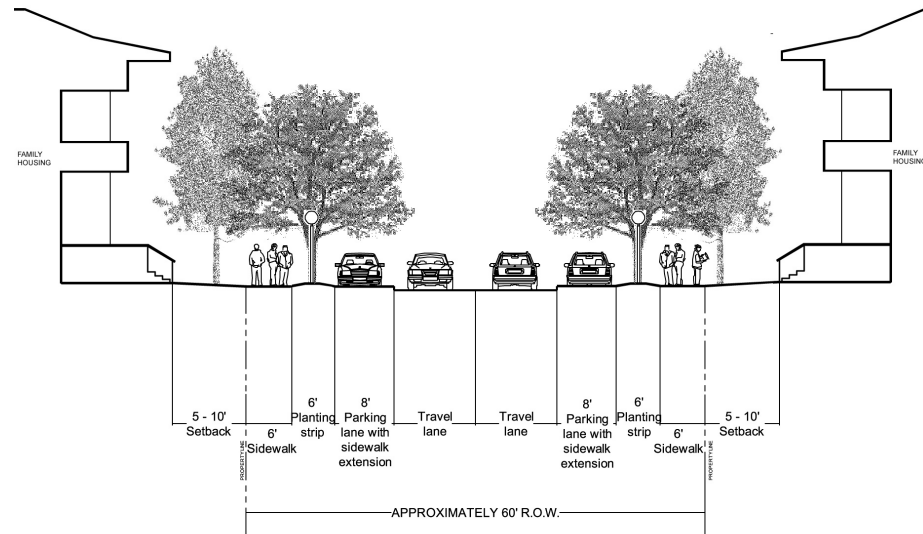

Figure 77 Local Access Streets ¹⁸

Pedestrian Connectors ¹⁹

Throughout the West Campus, a network of circulation corridors dedicated to pedestrian and bicycle movement and limited service and emergency access will be provided. These pedestrian connectors will be narrow in scale, generally 40 feet wide between buildings on either side. Within these corridors a pedestrian/bicycle path will be paved 20 feet wide to also safely accommodate emergency and light service vehicles. The pedestrian connectors will have pedestrian amenities such as pedestrian-scale lighting at adequate safety levels, benches and other street furniture, and will be informally planted with shade trees. Planting will reinforce views and create a clear visual linkage through the campus along these connectors. Like most areas of the West Campus, drought-tolerant ornamental shrubs, groundcovers and grasses (xeriscape) will be the dominant planting type. The use of lawn will be limited to specific functional areas such as adjacent children's play areas and passive relaxation areas along their corridor.

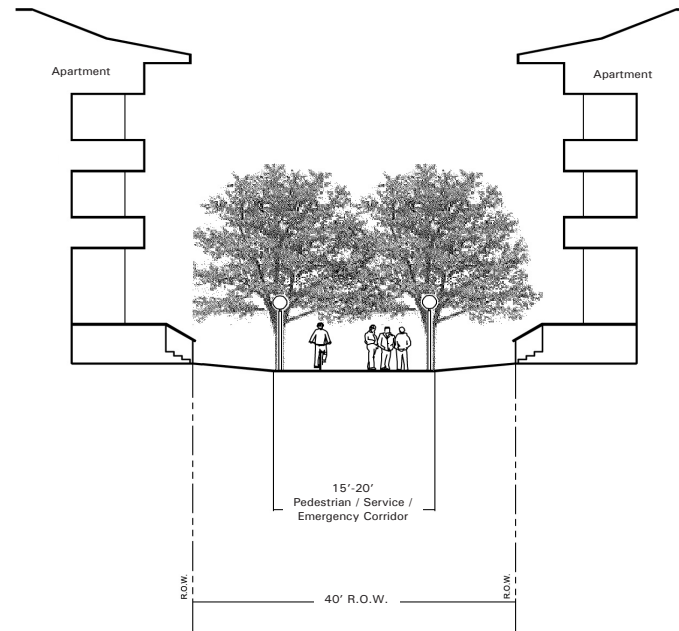
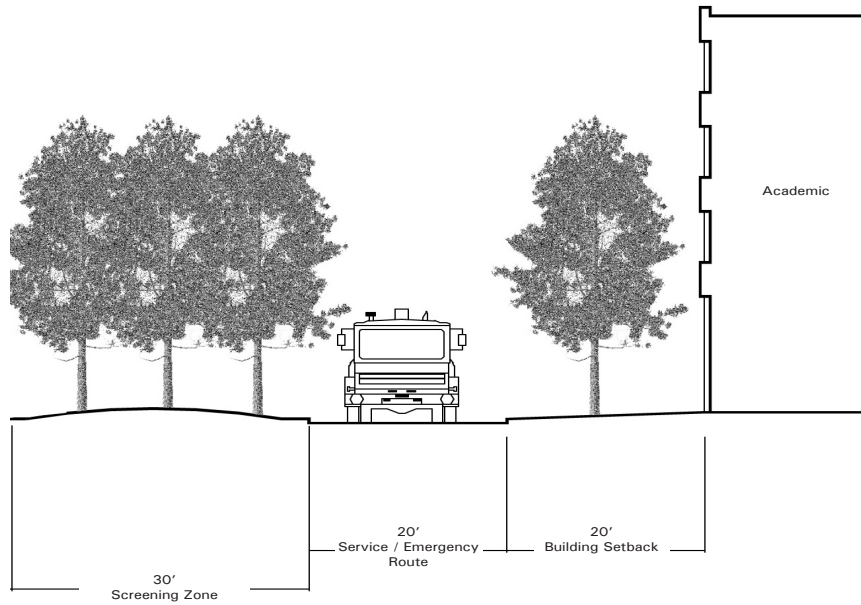

Figure 78 Pedestrian Connectors ¹⁹

Figure 79 Service Routes and Areas 10



Service Routes and Areas 10

Service roads are located throughout the West Campus academic core as described in the Circulation section of this report. Generally they are located away from major public areas. Therefore, landscape improvements for shade and aesthetic reasons are not of great importance unless such design will contribute to good sustainable building design practices (i.e., low building heat gain).

A few landscape guidelines for service roads and areas include:

- Screen service roads and service areas with dense plantings of drought-tolerant trees and shrubs in informal arrangements
- Where service routes must pass across pedestrian malls and spaces landscape materials such as paving, planting and lighting should be the same as the pedestrian space. The service route should not be delineated.
- Screen dumpsters and other refuse storage areas with walls or fence enclosures and dense plantings.

Gateways and Entries

There are several particularly important entries and gateways into the West Campus:

- Identity Gateways
- Arrival Gateways
- Major Pedestrian Gateways

In many cases the gateways serve as both vehicular and pedestrian gateways. However, generally one travel mode or another tends to be the dominant type for each gateway. Following is a description of each of these gateways and their intended landscape treatment.

Identity Gateways

Major vehicular gateways define the entrance to the West Campus to both those whose destinations are the University as well as through traffic. There are three identity gateways. These gateways are primarily locations for University identity signage and landscape improvements, and include the following:

- Eastbound intersection of Martin Luther King Boulevard and Chicago Avenue
- Southbound on Iowa Avenue at the University boundary
- University Avenue at the I-215/SR-60 undercrossing. This location has already been improved with signage on the overpass and serves as a gateway to the entire University campus.

Arrival Gateways

Major vehicular gateways serve as arrival points for visitors and the campus community to specific areas of the campus. They are focused on certain areas of the campus and serve varying functions. Therefore the landscape improvements at these gateways will vary. Generally, arrival gateways will be designed to have special planting and signage. Planting will provide the experience of passing through a portal or gateway and clearly differentiate the campus environment from the surrounding environment. Signage can be placed in the median or at the sides, but should be consistent with an overall campus sign program, and be easily visible.

Arrival gateways occur at seven places on the West Campus. Following is a discussion of each of these seven arrival gateway locations.

Figure 80 Canyon Crest Gateway

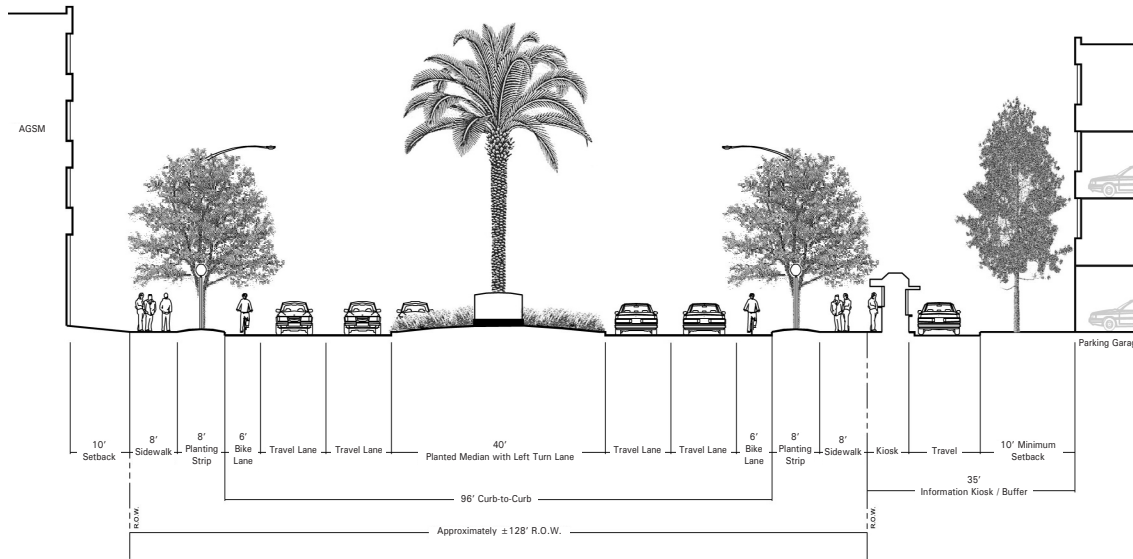

Canyon Crest Drive

Canyon Crest Drive is the primary arrival gateway on the West Campus for visitors. It also provides an important linkage between the East and West Campuses of UCR. With the Caltrans project to widen I-215/SR-60, the undercrossing at Canyon Crest Drive will also be widened and will ultimately accommodate two travel lanes in each direction, bike lanes in each direction, and widened sidewalks for pedestrians. These improvements will significantly improve the pedestrian environment in this important corridor.

In addition, further to the south nearer Martin Luther King, Canyon Crest Drive should be enhanced with additional planting and median treatment. In the future this will be a very important campus entry and should be treated as such with high level landscaping, signage and lighting.

Canyon Crest Drive will continue to be the location of the Information and Parking Kiosk. It will have a 5-lane cross section (2 lanes in each direction with planted median). It will be abundantly landscaped with plantings, lighting and signage that convey the image of the University’s rich citrus/agricultural history as well as a forward-looking research university. Plantings in this location need not be limited to drought-tolerant (xeriscape) in order to convey the importance of this arrival location.

Everton Place

This street will be both a local access street for adjacent residential uses as well as an important arrival gateway for visitors to the Conference Center and northern areas of the West Campus. Beginning at Iowa Avenue plantings, lighting and signage along this street will establish a linear gateway that is unique when compared with the other local access streets of the area. Palms or other major trees that are part of the major malls which set the landscape structure of the West Campus should not be used along this street.

Northwest Mall and Southwest Mall Gateways

In addition to providing open space connections between the West Campus residential and academic areas, these two malls also serve as arrival gateways to the professional

schools envisioned on the western side of the West Campus academic core. For a description of landscape improvements to these gateways see previous description in this section of the report.

Gage Gateway 12

Attractive, high visibility vehicular access to the professional schools near Martin Luther King Boulevard will be provided at the intersection of the street with the Gage Canal. This entry is envisioned as a ceremonial entry court that would contain short term visitor and VIP parking for up to 30 vehicles. Access to long term parking would be available along the service road which runs parallel to Martin Luther King Boulevard adjacent to the buffer zone. (See Circulation section and Landscape Buffers following.) The entry gateway and court will be richly landscaped using citrus, ornamental and native plantings, special lighting and signage. The design of the entry and court should relate to the buildings located on either side. Tall major plantings should extend to Martin Luther King Boulevard as a continuation of the Gage Mall and Grove Frame landscape.

Gateways to West Parking at Martin Luther King Boulevard (2 locations) 13

West of Gage Canal, two additional arrival gateways provide access to major parking facilities and the professional schools from Martin Luther King Boulevard at the west end of the academic core. Generally these entrances are more utilitarian in their function, providing vehicular access to major parking reservoirs. Landscape improvements at these locations will consist primarily of planted screening of the parking facilities and background lighting to provide for safety and security at night. Wayfinding signage to mark parking locations and to direct visitors to the parking areas will also be provided. Planting in this area will be drought-tolerant (xeriscape).

Figure 81 Gage Gateway 12

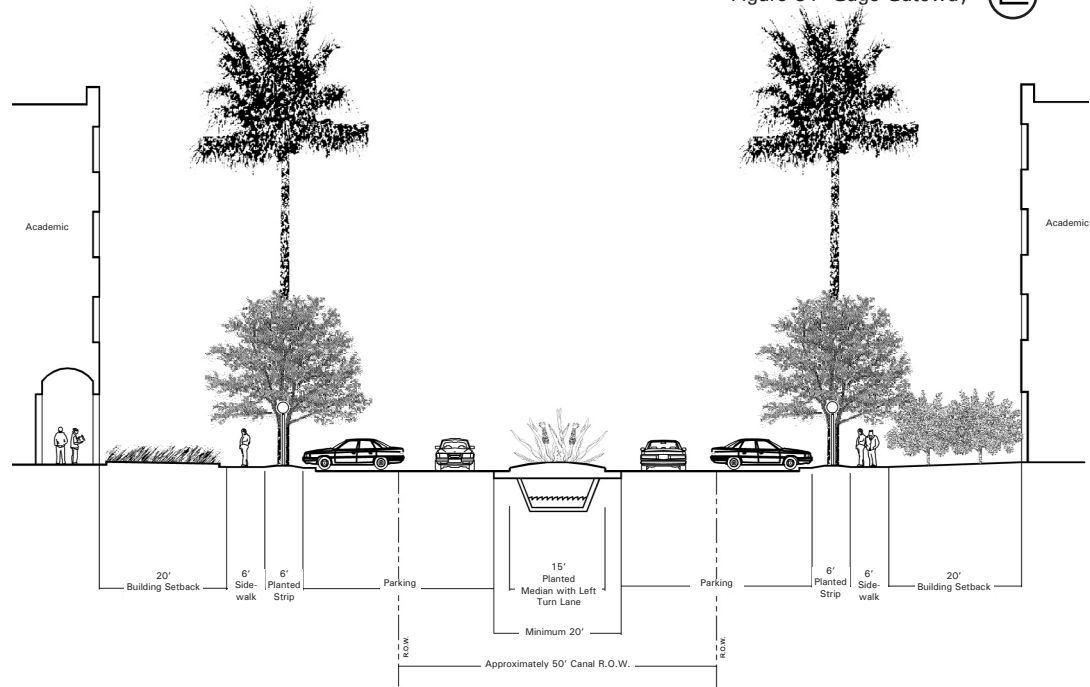
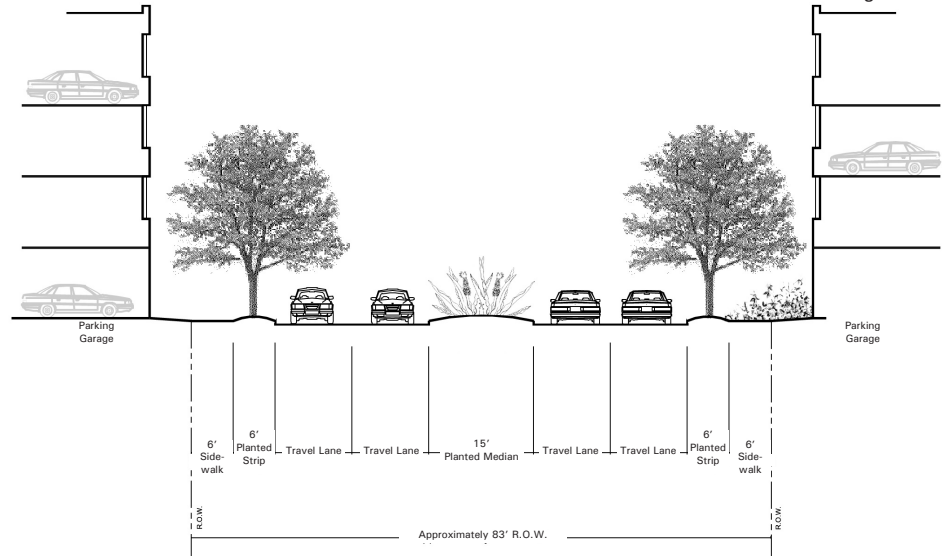

Figure 82 Gateways to West Parking at Martin Luther King Boulevard 13



Major Pedestrian Gateways

Major pedestrian gateways are those whose primary traffic is the students, faculty and staff of the UCR community. There are two primary pedestrian gateways to the West Campus:

- Canyon Crest Mall (via I-215/SR-60) undercrossing from the East Campus at Canyon Crest)
- University Mall (via the University Avenue freeway undercrossing from the East Campus)

Canyon Crest provides an important linkage between the East and West Campuses of UCR. With the Caltrans project to widen I-215/SR-60, this undercrossing will also be widened and will ultimately accommodate two vehicular travel lanes in each direction, bike lanes in each direction, and widened sidewalks for pedestrians. These improvements will significantly improve the pedestrian environment in this important corridor.

At the west end of the pedestrian undercrossing at the point where it intersects with the Canyon Crest Mall and Canyon Crest Drive, a gateway plaza/open space will be defined. The landscape of this plaza will be distinctive from that of the other areas, defining an arrival point for travelers from all three directions. Buildings at this location will be stepped back in plan on both sides of Canyon Crest Mall to define this plaza space. Improvements to the plaza will include shade trees and other ornamental plantings. It is not necessary to use primarily drought-tolerant plantings in this location in order to allow distinctive design from the landscape of the Canyon Crest Mall.

Landscape Buffers 14

In two areas of the West Campus incompatible land use adjacencies or the need for edge definition require that landscape buffers be provided. In both cases, it is envisioned that these buffers will be improved with multiple rows of large, fast-growing trees such as Eucalyptus or poplar to provide a visual screen. One buffer area is the I-215/SR-60 boundary line at the West Campus. A service road and building service areas are planned to face the freeway in this location. A buffer that varies in width from 30 feet to 100 feet containing large-scale trees will mitigate views of the freeway from windows of adjacent buildings and will enhance the image of the campus when viewed from the freeway

The other major West Campus buffer area is the south campus boundary along Martin Luther King Boulevard. This 100-foot wide buffer has several important roles to play as the southern edge to the West Campus including: 1) establish the image of the campus to many vehicles traveling along Martin Luther King Boulevard, and 2) screen the campus from Martin Luther King Boulevard, 3) provide an attractive linear connection for a hiking/jogging path, and 4) serve as an integral part of the stormwater drainage/detention system for the West Campus.

The landscape improvements of the Martin Luther King Boulevard buffer will have three general zones. Along Martin Luther King Boulevard extending approximately 10 feet into University land, a double row of street trees will provide a linear edge to the street and shade for the sidewalk. The center zone of the landscape buffer (approximately 60 feet wide) will contain a meandering naturalistic arroyo landscape. This arroyo landscape will be part of the stormwater drainage and detention system for the West Campus. It will include native and non-native plant materials, a sandy bottom and granite boulders to create a naturalistic appearance. Natural weirs and depressions will provide linear basins for detention and percolation following major storm events, similar to the design concept for the Northwest and Southwest Malls. Along this zone, running parallel to Martin Luther King Boulevard will be a meandering jogging/walking path of decomposed granite or similar material that crosses the

arroyo via culvert and bridges in various locations. This path will also provide linkages into the West Campus from Martin Luther King Boulevard at regular intervals. The remaining 30 feet of the buffer will be planted with large scale trees to screen the areas of campus buildings that front on The Grove in this location. The plantings will not be continuous, however. Intermittent breaks in the large scale planting will afford views of West Campus buildings, The Grove and major arrival gateways.

Figure 83 Landscape Buffer 14

